

DEPARTMENT OF HEALTH

NOTICE OF FINAL RULEMAKING

The Director of the Department of Health, pursuant to the authority set forth in Section 4902 of the Department of Health Functions Clarification Act of 2001 (“Act”) effective October 3, 2001 (D.C. Law 14-28; D.C. Official Code § 7-731(a)(11) (2012 Repl. & 2016 Supp.)), and Mayor’s Order 2001-111, dated August 6, 2001, hereby gives notice of the intent to amend the swimming pool and spa pool regulations in Title 25 (Food Operations and Community Hygiene Facilities), Subtitle C (Swimming Pool and Spa Regulations) of the District of Columbia Municipal Regulations (DCMR), by repealing the current regulations in Chapter 64 (Swimming Pools and Spas) of Title 25-C in its entirety, and establishing in its place new “Aquatic Facilities Regulations: Swimming Pools, Spa Pools, and Saunas” in Chapters 1 through 10 and 99 of Title 25-C DCMR.

The proposed rulemaking updates the existing regulations to reflect new industry standards and District regulations. Most significantly, the proposed rulemaking incorporates industry standards that are included in the second edition of the “Model Aquatic Health Code” published by the U.S. Department of Health and Human Services, Centers for Disease Control and Prevention, as well as other industry standards.

On February 10, 2017, the Notice of Proposed Rulemaking was published in the *D.C. Register* at 64 DCR 001389. The Department did not receive any comments and no changes were made to this Notice of Final Rulemaking.

These rules were adopted as final on April 4, 2017 and will take effect immediately upon publication of this Notice in the *D.C. Register*.

Subtitle C, SWIMMING POOL AND SPA REGULATIONS, of Title 25 DCMR, FOOD OPERATIONS AND COMMUNITY HYGIENE FACILITIES, is amended in its entirety to read as follows:

**SUBTITLE C AQUATIC FACILITIES REGULATIONS:
SWIMMING POOLS, SPA POOLS, AND SAUNAS**

CHAPTER 1 TITLE, INTENT, SCOPE

- 100 Title — Aquatic Facilities Regulations: Swimming Pools, Spa Pools, and Saunas**
- 101 Intent — Safety**
- 102 Compliance with District Laws, Federal Laws, and Industry Standards/Guidelines**

CHAPTER 2 GENERAL PROVISIONS

- 200 General Provisions — Swimming Pool Supervision & Posting Requirements***

- 201 General Provisions — Swimming Pool Admission Rules, Signs, & Postings*
- 202 General Provisions — Spa Pool and Sauna Admission Rules, Signs, & Postings*
- 203 General Provisions — Aquatic Facilities, Food and Beverage Consumption, Prohibitions

CHAPTER 3 TRAINING & CERTIFICATIONS, DUTIES, FACILITY POSTINGS & USE RESTRICTIONS, AND CHILD SAFETY PLAN*

- 300 Pool and Spa Operator — Training and Certifications, & Department Issued Registration Card*
- 301 Lifeguards — Duties**
- 302 Lifeguards and Swimming Instructors — Training and Certifications*
- 303 Lifeguard Requirements — Swimming Pool, Restricted Use
- 304 Additional Lifeguard Requirements — Bather Load, Pool Size, Visual Obstructions, and Dimensions
- 305 Child Safety Plan

CHAPTER 4 WATER QUALITY, CIRCULATION SYSTEMS, AND REPORTING REQUIREMENTS

- 400 Water Quality — Approved Source*
- 401 Water Quality — Standards, Drinking Water*
- 402 Water Quality — Standards, Clarity, Depth Markers, and Temperature*
- 403 Water Quality — Standards, Bacteriological*
- 404 Water Quality — Standards, Chemical Quality*
- 405 Water Quality — Test Kits
- 406 Water Quality — Contamination
- 407 Recirculation and Treatment System — Cross-Connection Prevention
- 408 Recirculation and Treatment System — Spa Pool and Sauna Turnover Rates & Plumbing System*
- 409 Circulation Systems — Public Swimming Pools, Turnover Rates*
- 410 Circulation System — Aquatic Recreation Facilities’ Turnover Rates, and Skimming Systems*
- 411 Water Supply and Wastewater Disposal — Contaminants, Removal
- 412 Reporting Requirements — Daily Water Quality & Safety Logs
- 413 Reporting Requirements — Emergency Notifications

CHAPTER 5 EQUIPMENT, EQUIPMENT ROOM, STORAGE AND MAINTENANCE, AND SAFETY

- 500 Equipment Rooms — Security Access*
- 501 Equipment Rooms — Floor Covering*
- 502 Equipment Rooms — Ventilation and Access*

- 503 **Equipment and Equipment Rooms — Size, Lighting, Maintenance and Good Repair, & Prohibited Items***
- 504 **General and Emergency Pool Lighting Requirements**
- 505 **First Aid and Safety Equipment**

CHAPTER 6 PLUMBING SYSTEMS, PHYSICAL STRUCTURE, DESIGN, ACCOMODATIONS, FACILITY MAINTENANCE, AND PEST CONTROL

- 600 **Physical Structure — Building Materials and Workmanship**
- 601 **Plumbing Systems — Design, Construction, Installation, and Cleanable Fixtures***
- 602 **Plumbing Systems — Water Temperature & Flow, Numbers, and Prohibitions***
- 603 **Toilet Facilities — Required Signage**
- 604 **Shower Facilities, Dressing Rooms — Reasonable Accommodations**
- 605 **Facility Maintenance — Physical Structure, Materials, Cleanability, and Prohibitions**
- 606 **Facility Maintenance — Toilet Facilities (Restrooms), Shower Facilities, Dressing Rooms, Handwashing Sinks, Access, and Prohibitions***
- 607 **Facility Maintenance — Equipment, Chemical Supplies, Use, Labeling, and Access***
- 608 **Facility Maintenance — Chemicals, Handling, Storage, and Safety***
- 609 **Facility Maintenance — Eye Wash Stations, Installation, Accessibility, Maintenance, and Training**
- 610 **Facility Maintenance — Effective Barriers, Fences***
- 611 **Facility Maintenance — Controlling Pests***
- 612 **Facility Maintenance — Removing Dead or Trapped Birds, Insects, Rodents, & Other Pests, and Animal Prohibition***

CHAPTER 7 APPLICATION & LICENSING REQUIREMENTS, AND DEFINITIONS

- 700 **Licenses, Registrations, & Certifications, and Certificate of Occupancy Requirements***
- 701 **Application Procedures for Facility License — Form of Submission, Notice**
- 702 **Application Procedures for Facility License — Contents of the Application Packet**
- 703 **Application Procedures — Denial of Application for Facility License, Notice**
- 704 **Issuance of Pool and Spa Operators’ Registration Cards**
- 705 **Issuance of Facility License – Required Plan Reviews and Approvals**
- 706 **Issuance of New and Renewal Facility Licenses – Existing Facility, New Construction, Renovation, and Retrofitting of Swimming Pools, Spa Pools, or Sauna Facilities**
- 707 **Issuance of Facility License – Existing Facilities, and Change in Ownership, or Location**
- 708 **Required Postings**

- 709 Licenses and Permits Not Transferable*
- 710 Access & Inspections – Department’s Right of Entry, Denial, and Inspectors’ Competency*
- 711 Report of Findings – Specifying Time Frame for Corrections
- 712 Report of Findings – Issuing Report and Obtaining Acknowledgement of Receipt
- 713 Report of Findings – Refusal to Sign Acknowledgement
- 714 Report of Findings – Public Information, Records Retention
- 715 Imminent Health Hazards – Ceasing Facility Operations and Emergency Reporting*
- 716 Imminent Health Hazard – Resumption of Facility Operations*
- 717 Critical Violations – Time Frame for Correction
- 718 Critical Violations – Verification and Documentation of Corrections
- 719 Noncritical Violations – Time Frame for Correction
- 720 Request for Reinspection

CHAPTER 8 ADMINISTRATIVE ENFORCEMENT ACTIONS AND ORDERS

- 800 Administrative Enforcement Action – Remedies
- 801 Administrative Enforcement Action – Condemnation Order, Justifying Conditions and Removal of Equipment, Chemicals, or Other Operational Supplies
- 802 Administrative Enforcement Action – Condemnation Order, Contents
- 803 Administrative Enforcement Action – Condemnation Order, Official Tagging or Marking of Equipment, Chemicals, or Other Operational Supplies
- 804 Administrative Enforcement Action – Condemnation Order, Equipment, Chemicals, or Other Operational Supplies May Not Be Used or Moved
- 805 Administrative Enforcement Action – Condemnation Order, Removing the Official Tag or Marking
- 806 Administrative Enforcement Action – Condemnation Order, Warning or Informal Conference Not Required
- 807 Administrative Enforcement Action – Summary Suspension of License, Conditions Warranting Action
- 808 Administrative Enforcement Action – Contents of Summary Suspension Notice
- 809 Administrative Enforcement Action – Summary Suspension, Warning or Informal Conference Not Required
- 810 Administrative Enforcement Action – Summary Suspension, Time Frame for Reinspection
- 811 Administrative Enforcement Action – Summary Suspension, Term of Suspension, Reinstatement
- 812 Administrative Enforcement Action – Revocation or Suspension of License, or Denial of Application or Renewal of License

CHAPTER 9 SERVICE OF PROCESS

- 900 Service of Process – Notice, Proper Methods**
- 901 Service of Process – Department Issued Notices of Summary Suspension, Notices of Infraction, and Other Directives**
- 902 Service of Process – Notice, Effectiveness**
- 903 Service of Process – Proof of Proper Service**

CHAPTER 10 ADMINISTRATIVE AND CIVIL PENALTIES, AND JUDICIAL REVIEW

- 1000 Notice of Infractions**
- 1001 Civil Fines and Penalties**
- 1002 Judicial Review – Appeals**
- 1003 [RESERVED – Fee and Service Schedule]**

CHAPTER 99 DEFINITIONS

- 9999 Definitions – General Provision and Definitions**

CHAPTER 1 TITLE, INTENT, SCOPE

100 TITLE – AQUATIC FACILITIES REGULATIONS: SWIMMING POOLS, SPA POOLS, AND SAUNAS

100.1 These provisions shall be known as the Aquatic Facilities Regulations: Swimming Pools, Spa Pools, and Saunas hereinafter referred to as “these regulations.”

101 INTENT – SAFETY

101.1 The purpose of these regulations is to prevent disease, sanitary nuisances, and accidents that threaten or impair the public’s health and safety, and to prevent any modifications that result in unsanitary operations or danger to public health or safety.

101.2 These regulations prescribe minimum design, construction, and operation requirements that are intended to protect the health and safety of the public in swimming pools and spas.

101.3 The Department shall regulate certain aspects of the design, equipment, operation, installation, new construction and rehabilitation of swimming pools, spa pools, and saunas. Where adequate standards do not exist and these regulations do not provide sufficient guidance for consideration of innovations in design, construction and operation of proposed swimming pools, spa pools, and saunas, the Department will establish requirements necessary to protect the health and safety of patrons.

- 101.4 These regulations establish definitions; set quality control standards for personnel, health, sanitary operations, equipment and facilities; provide for the issuance of licenses and certifications and inspections; and provide for enforcement through suspension and revocation of licenses and certifications, condemnation of equipment, and fines and penalties.
- 101.5 These regulations shall not apply to:
- (a) A swimming pool, spa pool, or sauna that is less than twenty-four inches (24 in.) (six hundred and ten millimeters (610 mm)) deep or that has a surface area less than two hundred fifty (250) square feet (twenty-three and twenty-five squared meters (23.25m²)), except when permanently equipped with a water-recirculating system or constructed with structural materials;
 - (b) Private single family residential swimming pools, spa pools, and saunas as regulated by the Department of Consumer and Regulatory Affairs (DCRA), and as defined in these Regulations;
 - (c) A swimming pool, spa pool, or sauna which is completely emptied of water, disinfected, and refilled with water between each use and that is intended for use or used by a single individual during each use; or
 - (d) A swimming pools, spa pools, or saunas that are operated for medical treatment or physical therapy, and water therapy facilities under the direction and control of medical personnel licensed pursuant to Section 501 of the Health Occupations Revision Act of 1985 Amendment Act of 1994, effective March 23, 1995 (D.C. Law 10-247; D.C. Official Code § 3-1205.01 (2016 Repl.)), as defined in these Regulations.
- 101.6 Certain provisions of these regulations are identified as critical. Critical provisions are those provisions where noncompliance serves as a vector for a waterborne illness, or an environmental health hazard. A critical item is denoted with an asterisk (*).
- 101.7 Certain provisions of these regulations are identified as noncritical. Noncritical provisions are those provisions where noncompliance is less likely to serve as a vector for a waterborne illness, or an environmental health hazard. A headnote that is denoted in these regulations without an asterisk (*) is a noncritical item. However, a critical item may have a provision within it that is designated as a noncritical item with a superscripted letter “N” following the provision.
- 102 COMPLIANCE WITH DISTRICT LAWS, FEDERAL LAWS, AND INDUSTRY STANDARDS/GUIDELINES**

- 102.1 The most recent versions of District and federal laws and regulations or any successor standards are hereby incorporated by reference:¹
- (a) The Virginia Graeme Baker Pool and Spa Safety Act of 2007, approved December 19, 2007 (Pub.L.110-140);
 - (b) 40 CFR Part 141 – National Primary Drinking Water Regulations;
 - (c) National Sanitation Foundation NSF-ANSI Standard 60-2005 Drinking Water Treatment Chemicals – Health Effects;
 - (d) Department of Justice (DOJ) 2010 Americans with Disabilities Act Accessibility Standards, 28 CFR Part 36, Subpart D, effective March 15, 2012;

¹ Section 102.1 cites to copyrighted materials that are not republished in these regulations. However, these materials are available on their respective websites, as follows:

- The Virginia Graeme Baker Pool and Spa Safety Act of 2007, approved December 19, 2007 (Pub.L.110-140) (<http://des.sh.gov/organization/divisions/water/wmb/pools/documents/vgb-act.pdf>)
- National Sanitation Foundation NSF-ANSI Standard 60-2005 Drinking Water Treatment Chemicals – Health Effects (<http://www.nsf.org/services/by-industry/water-wastewater/water-treatment-chemicals/nsf-ansi-standard-60>)
- National Sanitation Foundation NSF/ANSI Standard 50-2007 Circulation System Components and Related Materials for Swimming Pools, Spas/Hot Tubs, dated April 2007, approved substitute filters (http://standards.nsf.org/apps/group_public/download.php/458/50i51r1.pdf)
- American National Standard ASME A112.19.8 - 2007 Suction Fittings For Use in Swimming Pools, Wading Pools, Spas, and Hot Tubs published by the American Society of Mechanical Engineers; performance standard (<http://www.poolsafely.gov/wp-content/uploads/2016/04/pssa.pdf>)
- ASME/ANSI standard A112.19.7 Safety Standard Vacuum Release System or ASTM standard F2387 (<http://www.poolsafely.gov/wp-content/uploads/2016/04/pssa.pdf>)
- American National Standard Specifications for Ceramic Tile A137.1-2012 (Dynamic Coefficient of Friction Specification and Testing for Slip Resistance) (<http://www.tcnatile.com/>)
- U.S. Consumer Product Safety Commission (CPSC) Publication No. 362 Guidelines, entitled “Safety Barrier Guidelines for Home Pools; and any other pool safety guidelines established by the Commission (http://www.anotherperfectpoolnews.com/wp-content/CPODocs/VGB_Handout.pdf)
- U.S. Department of Health and Human Services, Centers for Disease Control and Prevention (CDC) “The Model Aquatic Health Code” 2nd Edition (July 2016) (<http://www.cdc.gov/mahc/currentedition/index.html>)
- National Collegiate Athletic Association (NCAA), 2012 – 2013 (<http://www.ncaa.org/>)
- National Federation of State High School Associations, 2015 – 2016 (<https://www.nfhs.org/activities-sports/swimming-diving/>)

- (e) National Sanitation Foundation NSF/ANSI Standard 50-2007 Circulation System Components and Related Materials for Swimming Pools, Spas/Hot Tubs, dated April 2007, approved substitute filters;
- (f) American National Standard ASME A112.19.8 - 2007 Suction Fittings For Use in Swimming Pools, Wading Pools, Spas, and Hot Tubs published by the American Society of Mechanical Engineers; performance standard;
- (g) ASME/ANSI standard A112.19.7 Safety Standard Vacuum Release System or ASTM standard F2387;
- (h) American National Standard Specifications for Ceramic Tile A137.1-2012 (Dynamic Coefficient of Friction Specification and Testing for Slip Resistance);
- (i) U.S. Consumer Product Safety Commission (CPSC) Publication No. 362 Guidelines, entitled “Safety Barrier Guidelines for Home Pools; and any other pool safety guidelines established by the Commission;
- (j) U.S. Department of Health and Human Services, Centers for Disease Control and Prevention (CDC) “The Model Aquatic Health Code” 2nd Edition (July 2016);
- (k) National Collegiate Athletic Association (NCAA), 2012 - 2013;
- (l) National Federation of State High School Associations, 2015 - 2016; and
- (m) The District of Columbia’s Construction Codes Supplements of 2013, Title 12 of the District of Columbia Municipal Regulations, (61 DCMR 3453 (March 28, 2014 – Part 2)); which consist of the following International Code Council (ICC):²

²

The International Council Codes are copyrighted and are not republished in these Regulations. However, copies of the International Council Codes, as amended by the District of Columbia’s Construction Codes Supplements of 2013, are available on the following websites:

- (a) The District of Columbia Building Supplement (2013) (12 DCMR A)
(<http://publicecodes.cyberregs.com/icod/ibc/2012/index.htm?bu=IC-P-2012-000001&bi2=IC-P-2012-000019>)
- (b) The District of Columbia Mechanical Code Supplement (2013)(12 DCMR E)
(<http://publicecodes.cyberregs.com/icod/imc/2012/index.htm?bu=IC-P-2012-000005&bu2=IC-P-2012-000019>)
- (c) The District of Columbia Plumbing Code Supplement (2013)(12 DCMR F)
(<http://publicecodes.cyberregs.com/icod/ipc/2012/index.htm?bu=IC-P-2012-000005&bu2=IC-P-2012-000019>)
- (d) The District of Columbia Fire Code Supplement (2013)(12 DCMR H)
(<http://publicecodes.cyberregs.com/icod/ifc/2012/index.htm?bu=IC-P-2012-000005&bu2=IC-P-2012-000019>)
- (e) The District of Columbia Electrical Code Supplement (2013)(12 DCMR C)
(<http://www.nfpa.org>)
- (f) The District of Columbia Swimming Pool and Spa Code Supplement (2013)(12 DCMR L)

- (1) International Building Code (2012 edition);
- (2) International Mechanical Code (2012 edition);
- (3) International Plumbing Code (2012 edition);
- (4) International Fire Code (2012 edition);
- (5) International Existing Building Code (2012 edition);
- (6) International Swimming Pool and Spa Code (2012 edition); and
- (7) The National Fire Protection Association (NFPA) National Electrical Code (2014 edition).

102.2 If a conflict arises between a provision in these regulations and a federal law or regulation cited in Subsection 102.1 above, the federal law or regulation shall take precedence over these regulations. However, where there is a conflict between provisions in these regulations, the International Codes or their referenced standards, or the District's Construction Codes Supplements, the District's Construction Codes Supplements, including standards and amendments, shall take precedence.

102.3 In enforcing the provisions of these regulations, the Department shall regulate certain aspects of a public swimming pool, spa pool, or sauna's physical structure; operating systems, equipment, devices, fixtures, supplies, or furnishings in use before the effective date of these regulations based on the following considerations:

- (a) Whether the establishment's physical structure; operating systems, equipment, devices, fixtures, supplies, or furnishings used in the public swimming pool, spa pool, or sauna, is in good repair or capable of being maintained in a hygienic condition in compliance with these regulations; or
- (b) The existence of a documented agreement with the licensee that the physical structure; operating systems, equipment, devices, fixtures, supplies, or furnishings used in public swimming pool, spa pool, or sauna will be replaced by an agreed upon date.

<http://pullicecodes.cyberregs.com/icod/ispsc/2012/index.htm?bu=IC-P-2012-000005&bu2=IC-P-2012-000019>

(g) The District of Columbia Existing Building Code
<http://pullicecodes.cyberregs.com/icod/iebc/2012/index.htm?bu=IC-P-2012-000006&bu2=IC-P-2012-000019>

CHAPTER 2 GENERAL PROVISIONS

200 GENERAL PROVISIONS — SWIMMING POOL SUPERVISION & POSTING REQUIREMENTS*

200.1 The licensee may employ the services of a swimming pool Management Company to fulfill the requirements of these regulations.

200.2 All licensees, pool and spa operators, lifeguards or swimming instructors in charge of, or working at, public swimming pools shall be responsible for the supervision and swimming pool.

200.3 The licensee shall ensure that pool and spa operators, lifeguards or swimming instructors possess current first aid training certificates as specified in Subsections 302.3 and 302.4 of these regulations, and that pool and spa operators possess valid certificates issued by the Mayor as required in Subsection 700.4 of these regulations.

200.4 A licensee shall ensure that an individual functioning as both a lifeguard and pool and spa operator is in compliance with the requirements identified in Sections 200.3, 300, 301, 302, 304, 412.5, 412.7, 413.1, 704 and 710.3 of these regulations.

200.5 A licensee shall ensure swimming pools that are two hundred square feet (200 sq. ft.) in area or greater without an approved diving well configuration post a sign in letters that are four inch (4 in.) (one hundred and two millimeters (102 mm)) in height, which states:

“NO DIVING”

200.6 A licensee shall ensure swimming pools where the pool depth is five feet (5 ft.) (1524 mm) or less, a sign displaying “No Diving” symbol shall be posted:



200.7 The “No Diving” symbol in Subsection 200.6 or similar symbol shall be posted on the deck at intervals of not more than twenty-five feet (25 ft.) (seven thousand, six hundred and twenty millimeters (7620 mm)).

201 GENERAL PROVISIONS — SWIMMING POOL ADMISSION RULES, SIGNS, & POSTINGS*

201.1 Rules for the admission of bathers to the swimming pool shall be enforced and shall have a heading or caption that reads “Pool Rules” printed legibly with letters

that are three inches (3") or larger on a backing of durable construction and conspicuously posted in an appropriate location for all bathers to see before entering the swimming pool. The sign shall state the following:

- (a) No tobacco products, drink, glass or animals in the pool deck area;
- (b) Bathing load: ____ persons;
- (c) Pool hours: ____ a.m. to ____ p.m.;
- (d) Shower before entering pool area;
- (e) Do not swallow the pool water; and
- (f) The Pool and Spa Operator at this facility is _____ District Permit number _____.

201.2 Pool closed signs shall be provided and posted at bather entrances whenever a swimming pool's operating license is summarily suspended for water quality or safety violations.

201.3 All swimming pools shall post a sign for all bathers to see before entering the swimming pool area directing bathers to shower before entering the pool.

201.4 In addition to Subsection 201.1, licensees, pool and spa operators, lifeguards, and swimming instructors shall enforce the following rules including but not limited to:

- (a) Restricting the introduction of dirt, excreta, and other extraneous matter into the water by bathers;
- (b) Excluding persons from the swimming pool who are intoxicated, and persons who show apparent signs of infection, such as open cuts, wounds, rashes, or blisters.
- (c) Restricting the importation of dangerous objects and materials into the swimming pool area;
- (d) Prohibiting smoking, and unsafe acts, both in and out of the water;
- (e) Prohibiting the use of topical agents including oils, body lotions, and minerals prior to entering, or while in the water. Waterproof sunscreens are allowed when applied and re-applied according to the manufacturers' recommendations;

- (f) The consumption of food or beverages is prohibited on the deck area and a three feet (3 ft.) clearance around the swimming pool, spa pool, or sauna perimeter shall be maintained at all times;
- (g) Ensuring that small children are water-safe, as defined in these regulations;
- (h) Ensuring that small children and frail individuals are properly supervised by a competent water-safe person in addition to the lifeguard; and
- (i) Requiring incontinent individuals to wear protective clothing and small children wearing diapers to also wear snugly-fitting rubber pants.

201.5 In addition to Section 201, when no lifeguard is on duty, a permanently mounted sign shall be printed legibly with letters that are three inches (3 in.) or larger conspicuously posted warning bathers of the following:

“WARNING – NO LIFEGUARD IS ON DUTY. SWIM AT YOUR OWN RISK.”

“NO CHILDREN UNDER THE AGE OF FIFTEEN (15) SHALL USE THE SWIMMING POOL WITHOUT ADULT SUPERVISION.”

“ADULTS SHOULD NOT SWIM ALONE.”

201.6 Wading pools that do not have a lifeguard inside the wading pool enclosure shall have a permanently mounted sign printed legibly with letters that are three inches (3 in.) or larger conspicuously posted which states:

“WARNING – NO LIFEGUARD ON DUTY.”

202 GENERAL PROVISIONS – SPA POOL AND SAUNA ADMISSION RULES, SIGNS, & POSTINGS*

202.1 Rules for the admission to spa pools and saunas shall be enforced and shall have a heading or caption that reads “Spa pools and Saunas Rules” printed legibly with letters that are three inches (3 in.) or larger conspicuously posted adjacent to the entrance to each hot water facility except where notice is provided to bathers pursuant to Subsections 201.1, 201.5, and 201.6. The sign shall state:

- (a) Post a sign which reads, “The Pool and Spa Operator at this facility is _____ District Permit number _____;”
- (b) Do not operate at water temperatures higher than one hundred and four degrees Fahrenheit (104° F) (forty degrees Celsius (40° C)). The actual

temperature of this spa pool at _____ o'clock today is _____ ° F
(_____ ° C) at three (3) hour intervals; and

- (c) Bathers shall shower prior to entering the spa pool or sauna;
- (d) The maximum number of bathers allowed in the spa or hot tub at one time is _____. The maximum bather load shall be determined on the basis of nine square feet (9 sq. ft.) of water surface per bather;
- (e) “Risk of Drowning”;
- (f) Unsupervised use by children is prohibited;
- (g) Do not use alone;
- (h) Always enter and exit slowly and cautiously;
- (i) Bathers with a history of heart disease, diabetes, high or low blood pressure or who are pregnant should consult their physician prior to use;
- (j) Bathers on medication should consult with their physician prior to use;
- (k) Observe a reasonable time limit of 10 – 15 minutes, then shower upon exiting the hot water facility, cool down and rest before returning for another brief stay;
- (l) Long exposure may result in discomfort, nausea, dizziness or fainting, a shorter exposure period is recommended when a bather is pregnant;
- (m) Do not use while smoking, or under the influence of alcohol, drugs, medicines, or anything else that may impair the senses or cause drowsiness;
- (n) Do not use electrical appliances or devices within five feet (5 ft.) of a spa pool or sauna;
- (o) Do not use topical agents including, oils, body lotions, and minerals prior to entering, or while in the water. Waterproof sunscreens are allowed when applied and re-applied according to the manufacturers’ recommendations; and
- (p) Bathers with apparent signs of infection or other evidence of high contamination risk, such as open cuts, wounds, rashes, or blisters are excluded, except when certified by a physician not to be in a communicable stage.

202.2 A clock or other time-keeping device that is maintained and in good working condition shall be provided on the deck area and visible to bathers from any location within the spa pool or sauna.

203 GENERAL PROVISIONS — AQUATIC FACILITIES, FOOD AND BEVERAGES CONSUMPTION, PROHIBITIONS*

203.1 The consumption of food or beverages is prohibited, except for areas specifically designated as eating areas that are separated from the swimming pool, spa pool, or sauna, as specified in Subsection 201.4(f).

203.2 Aquatic facilities that serve food or beverages shall not use containers made of glass or other material which, when broken, could be a hazard to bathers.

203.3 Only water bottles made of non-glass and non-breakable material are allowed on pool decks, and shall not be used by patrons while swimming inside the swimming pool.

203.4 Swimming pools and pool deck areas shall be closed to the public during competitive swimming practices and/or swimming competitions.

CHAPTER 3 TRAINING & CERTIFICATIONS, DUTIES, FACILITY POSTINGS & USE RESTRICTIONS, AND CHILD SAFETY PLAN*

300 POOL AND SPA OPERATOR — TRAINING AND CERTIFICATIONS, & DEPARTMENT ISSUED REGISTRATION CARD*

300.1 A pool and spa operator shall be on duty during all hours the aquatic facility is open to the public.

300.2 Individuals who maintain the cleanliness, water quality and chemical balance of public swimming pools, spa pools, or saunas shall obtain a Pool and Spa Operator Registration Card issued by the Department.

300.3 Individuals desiring to become pool and spa operators shall attend a training course approved by the Department of Health.

300.4 Course training shall include the following study topics:

- (a) Swimming pool and spa pool calculations;
- (b) Filter type and filtration circulation;
- (c) Water chemistry – balancing & testing;
- (d) Spa pools and warm water pools;

- (e) Swimming pool and spa pool maintenance;
 - (f) Operational and safety requirements; and
 - (g) Aquatic Facilities Regulations: Swimming Pools, Spa Pools, and Saunas, Title 25-C of the District of Columbia Municipal Regulations (DCMR).
- 300.5 A pool and spa operator shall demonstrate knowledge of public pools, which includes but is not limited to:
- (a) Swimming pool and spa pool cleaning;
 - (b) General pool maintenance;
 - (c) Make-up water supply; and
 - (d) Bacteriological, chemical, and physical quality of water and water purification, testing, treatment, and disinfection procedures.
- 300.6 Certification does not imply any licensure as a contractor regulated by the Department of Consumer and Regulatory Affairs.
- 300.7 A pool and spa operator may not affect the structural integrity of the pool or equipment, and shall not delegate work to others, including employees that are not themselves certified under these regulations.
- 300.8 The Department shall issue Pool and Spa Operators' Registration Cards that are renewed every three (3) years.

301 LIFEGUARDS – DUTIES*

- 301.1 Where required, lifeguards shall be on the deck and shall observe the pool whenever bathers are in the water or on the pool deck.
- 301.2 Lifeguards shall be properly attired and readily identifiable as members of the lifeguard staff.
- 301.3 Lifeguards shall not leave their post for any reason without ensuring that all bathers are out of the water and that they will not return to the water during the lifeguard's absence.

302 LIFEGUARDS AND SWIMMING INSTRUCTORS – TRAINING AND CERTIFICATIONS*

- 302.1 Lifeguards and swimming instructors shall receive first aid training, including but not limited to:
- (a) Basic treatment of bleeding, shock, sudden illness, and muscular/skeletal injuries as per the guidelines of the National First Aid Science Advisory Board;
 - (b) Knowing when and how to contact the District of Columbia Fire and Emergency Medical Services Department (DCFEMS);
 - (c) Rescue and emergency care skills to minimize movement of the head, neck and spine until DCFEMS arrives for a person who has suffered a suspected spinal injury on land or in the water; and
 - (d) Use and the importance of universal precautions and personal protective equipment in dealing with body fluids, blood, and preventing contamination according to current OSHA guidelines.
- 302.2 Lifeguards and swimming instructors' training in and use of Cardio-Pulmonary Resuscitation and Automated External Defibrillator (CPR/AED), Automated External Defibrillator (AED) and other resuscitation skills shall be professional level skills that follow treatment protocols consistent with the current Emergency Cardiovascular Care Update (ECCU) and/or, the International Liaison Committee on Resuscitation (ILCOR) guidelines for cardiac compressions, foreign body restriction removal, and rescue breathing for infants, children, and adults.
- 302.3 Lifeguards and swimming instructors shall maintain current certifications in lifeguarding or swimming instruction by:
- (a) The American Red Cross;
 - (b) The YMCA or other equivalent nationally recognized aquatic training organization that meets the established standards, objectives and standards of care provided in the American Red Cross or YMCA programs; or
 - (c) Other nationally recognized aquatic training organizations adopted and recognized by the D.C. Department of Health.
- 302.4 Lifeguards and swimming instructors shall possess current certificates in First Aid; and Adult, Child and Infant Cardio-Pulmonary Resuscitation and Automated External Defibrillator (CPR/AED) through the American Red Cross, the American Heart Association, the National Safety Council, the American Academy of Orthopedic Surgeons, or other nationally recognized aquatic training organizations adopted and recognized by the D.C. Department of Health.

302.5 Swimming coaches are exempted from the swimming instructor certification requirement when training advanced level swimmers for competition.

303 LIFEGUARD REQUIREMENTS — SWIMMING POOL, RESTRICTED USE

303.1 Except as provided in Sections 303.2 and 305, a lifeguard shall not be required for a swimming pool that is:

- (a) Open for use only to persons who hold membership or other paid association in the facility where the pool is located;
- (b) Open for use only to persons who are permanent or temporary residents or guests of residents at the facility where the pool is located;
- (c) Open for use to persons who are lodging for a fee at the facility where the pool is located; or
- (d) A spa pool or sauna.

303.2 The exemptions identified in Subsection 303.1 shall not apply if a swimming pool has:

- (a) A diving board;
- (b) A depth of at least five feet (5 ft.) (one and one-half meters (1.5 m)) for non-municipal pools;
- (c) An expected bather population of fifty percent (50%) or more children under the age of fifteen (15); or
- (d) New construction occurring from the date of adoption of these regulations for any aquatic facility deeper than five feet (5 ft.) (one and one-half meters (1.5 m)) at any point.

304 ADDITIONAL LIFEGUARD REQUIREMENTS — BATHER LOAD, POOL SIZE, VISUAL OBSTRUCTIONS, AND DIMENSIONS

304.1 Except as specified in Section 303, there shall be a minimum of one (1) lifeguard on duty capable of observing the swimming pool for every fifty (50) bathers permitted in the water as specified in Table 403.1 of the 2012 International Swimming Pool and Spa Code (ISPSC).

**TABLE 403.1
MAXIMUM BATHER LOAD**

| POOL / DECK AREA | SHALLOW INSTRUCTIONAL OR WADING AREAS | DEEP AREA (NOT INCLUDING THE DIVING AREA) | DIVING AREA (PER EACH DIVING BOARD) |
|--|---------------------------------------|---|-------------------------------------|
| Pools with minimum deck area | 15 sq. ft. per user | 20 sq. ft. per user | 300 sq. ft. |
| Pools with deck area at least equal to water surface area | 12 sq. ft. per user | 15 sq. ft. per user | 300 sq. ft. |
| Pools with deck area at least twice the water surface area | 8 sq. ft. per user | 10 sq. ft. per user | 300 sq. ft. |

304.2 In addition to Subsection 304.1, when lifeguards are used, the aquatic facility’s staffing plans shall include diagrammed zones of patron surveillance that:

- (a) Ensures qualified lifeguards are capable of viewing the entire area of the assigned zone of patron surveillance;
- (b) Ensures qualified lifeguards are able to reach the furthest extent of the assigned zone of patron surveillance within twenty (20) seconds;
- (c) Identifies whether qualified lifeguards are in an elevated stand, walking, in-water, and/or other approved position;
- (d) Identifies any additional responsibilities for each zone;
- (e) All areas of an aquatic facility are assigned a zone of patron surveillance; and
- (f) Lifeguard zones of patron surveillance are required in aquatic facility plans submitted for review.

304.3 Pool management shall increase the number of lifeguards based on the number of bathers in the swimming pool.

304.4 The Department of Health may require a lifeguard to be on duty if none exists, or require additional lifeguards to be on the deck, or restrict swimming to one (1) portion of any swimming pool because of the following:

- (a) The number of lifeguards is inadequate to safely guard the swimming pool due to the number of bathers using the swimming pool;
- (b) The shape, dimension, and layout of the swimming pool and filter room locations;
- (c) The existence of an obstruction to vision; or

(d) The capability of the bathers using the swimming pool.

304.5 Swimming pools over eighteen hundred square feet (1800 sq. ft.) of water surface area shall have at least one (1) elevated lifeguard chair for each three thousand square feet (3000 sq. ft.) of swimming pool surface or fraction thereof. A deck-level lifeguard may be used in a designated area on the deck adjacent to shallow water instead of an elevated lifeguard chair.

304.6 Swimming pools with a width of forty-five feet (45 ft.) or more shall have more than one (1) lifeguard chair located on each side of the swimming pool.

304.7 The Department shall accept dimensional standards for competition type pools as published by the National Collegiate Athletic Association (NCAA), 2012 - 2013 or most recent addition; Fédération Internationale De Natation Amateur (FINA), 2015-2017 Handbook or most recent addition; 2015 - 2017 Official Technical Rules of United States Diving Inc. or most recent addition; 2015 United States Swimming Rules and Regulations or most recent addition, and National Federation of State High School Associations, 2015 - 2016 or most recent addition.

305 CHILD SAFETY PLAN

305.1 A swimming pool or spa that does not have a lifeguard on duty shall follow a Child Safety Plan that has been reviewed and approved by the Department during a preoperational inspection.

305.2 The Child Safety Plan shall contain the following information:

- (a) The name, address and telephone number of the facility;
- (b) The name, address and telephone number of the owner of the facility;
- (c) The facility's swimming season (the months of the year that the pool is open);
- (d) The expected number of bathers when the spa is open (daily average for the operating months);
- (e) The expected number of bathers who are over the age of fourteen (14) when the spa is open (daily average for the operating months);
- (f) The percentage of the expected bathers who are under the age of fourteen (14) when the spa is open (daily average for the operating months);

- (g) Specific measures that the facility will undertake (in addition to the posting of signs) to ensure that children under the age of fourteen (14) do not use the spa without adult supervision; and
- (h) Specific measures that the facility will undertake to monitor the spa when the spa is open.

CHAPTER 4 WATER QUALITY, CIRCULATION SYSTEMS, AND REPORTING REQUIREMENTS

400 WATER QUALITY – APPROVED SOURCE*

- 400.1 The only approved system for pool water shall be potable water from the District of Columbia public water system.
- 400.2 Existing aquatic facilities shall have at least one (1) drinking fountain directly plumbed and maintained in good repair or shall have at least one (1) water cooler inside the facility.
- 400.3 If a drinking fountain cannot be provided inside the aquatic facility, it shall be provided in a common use building or area adjacent to the aquatic facility entrance and on the normal path of bathers going to the aquatic facility entrance.

401 WATER QUALITY – STANDARDS, DRINKING WATER*

- 401.1 Potable water shall be used to supply water to all pools and shall meet the requirements of the applicable provisions of 40 CFR Part 141 – National Primary Drinking Water Regulations, and the District of Columbia drinking water quality standards.

402 WATER QUALITY – STANDARDS, CLARITY, DEPTH MARKERS, AND TEMPERATURE*

- 402.1 The pool water shall be 0.5 or less NTU and the main drain grate shall be readily visible from the pool deck.
- 402.2 The water in an aquatic facility shall be sufficiently clear such that the bottom is visible while the water is static at all times the aquatic facility is open or available for use.
- 402.3 Depth markers shall be not less than four inches (4 in.) (one hundred and two millimeters (102 mm)) in height. The color of the numbers shall contrast with the background on which they are applied and the color shall be of a permanent nature. The lettering shall spell out the words “feet” and “inches” or abbreviate them as “Ft.” and “In.” respectively. Where displayed in meters in addition to feet and inches, the word meter shall be spelled out or abbreviated as “M”.

- 402.4 Swimming pools built after adoption of these regulations, shall add a four inch by four inch square (4 in. x 4 in.) (10.2 cm x 10.2 cm) marker tile in a contrasting color to the swimming pool floor, and/or shall add a main suction cover outlined in a contrasting color to the swimming pool floor which are located at the deepest part of the swimming pool floor.
- 402.5 Swimming pools over ten feet (10 ft.) (3.0 m) deep, an eight inch by eight inch square (8 in. x 8 in.) (20.3 cm x 20.3 cm) marker tile in a contrasting color to the swimming pool floor or main suction outlet shall be located at the deepest part of the swimming pool.
- 402.6 Spa pools and swimming pools with heaters shall have a maximum water temperature of one hundred and four degrees Fahrenheit (104° F) (forty degrees Celsius (40° C)).

403 WATER QUALITY – STANDARDS, BACTERIOLOGICAL*

- 403.1 The pool water shall be free of coliform bacteria contamination.

404 WATER QUALITY – STANDARDS, CHEMICAL QUALITY*

- 404.1 The Department may collect water samples and examine them as necessary to determine compliance with these regulations.
- 404.2 Chemicals used in controlling the quality of the pool water shall be tested and approved using the National Sanitation Foundation (NSF-ANSI) Standard 60, 2005, which is incorporated by reference into these rules and shall be compatible with other accepted chemicals used in pools. The following parameters shall be adhered to when treating water for swimming pools, spa pools or saunas:
- (a) Maintain water pH between 7.2 to 7.8; however:
 - (1) Water pH shall not be below 6.5; or
 - (2) Water pH shall not be above 8.0;
 - (b) Use the following disinfectants –
 - (1) Free chlorine residual shall be 1 milligram per liter (mg/L) to 10 mg/L, inclusive, in conventional swimming pools.
 - (2) Free chlorine residual shall be 2 mg/L to 10 mg/L, inclusive, in all other type pools such as spa-type pools, except spa-type pools which shall be at the minimum of 3 mg/L.

- (3) Bromine residual shall be 1.5 mg/L to 8 mg/L, inclusive, in conventional swimming pools and 4 mg/L to 8 mg/L, inclusive, in all spa-type pools.
- (4) Except that, the following maximum disinfectant levels shall apply to indoor conventional swimming pools: 5 mg/L free chlorine or 6 mg/L bromine;
- (c) The level of combined Chlorine (Chloramines) use shall not exceed 0.4 ppm (mg/L) – Water with combined chlorine (chloramines) levels in excess of 0.4 ppm (mg/L) shall be reduced by the following actions:
 - (1) Super-chlorination; or
 - (2) Water exchange;
- (d) When oxidation reduction potential controllers are used – Water potential shall be kept between six hundred to nine hundred millivolts (600 – 900 mv). Use of these units does not negate the manual daily testing requirement of Section 412;
- (e) Use of cyanuric acid – shall remain between 30 and 50 mg/L and shall not exceed 100 ppm in swimming pools and in spa pools; and
- (f) Use of quaternary ammonium – 5 mg/L maximum.

404.3 Irrigation water that wets the deck area of a pool and the water in the pool shall be potable water. Non-potable irrigation water shall not be applied within ten feet (10 ft.) of the wet deck area.

404.4 Manual addition of chemicals will be allowed under special conditions and requires the pool to be closed prior to addition and for at least one (1) hour after addition, or a longer period as necessary, for sufficient and safe distribution of the chemical. After treatment for breakpoint chlorination and algae prevention, use of the pool can be resumed when the free chlorine levels drop to 10 mg/L, or in compliance with the Safety Data Sheets.

405 WATER QUALITY – TEST KITS

405.1 Water quality test kits such as colorimetric, titrimetric, turbidimetric, or electronic are required to be on the premises of all swimming pools and spa pools to determine free active chlorine and total chlorine using N,N-Diethyl-p-Phenylenediamine (DPD), or bromine level, total alkalinity, calcium hardness, and pH.

405.2 Water quality test kits shall be provided if the corresponding chemicals are used:

- (a) Cyanuric acid;
- (b) Sodium chloride;
- (c) Quaternary ammonium;
- (d) Ozone; and
- (e) Copper.

405.3 A single water quality test kit may be used for multiple pools, provided the pools have common ownership and they are located on contiguous property.

405.4 A water quality test kit shall be capable of measuring disinfectant levels in the normal operating range.

406 WATER QUALITY – CONTAMINATION

406.1 A swimming pool, spa pool, or sauna shall be deemed contaminated when one (1) of the following conditions exists:

- (a) More than one (1) ten milliliter (10 ml) portion of a sample shows a positive test for coliform organisms when multi-tube fermentation technique is used; or more than one (1) coliform per fifty milliliters (50 ml) when the membrane filter test is used; or
- (b) Two (2) consecutive samples show a positive test for coliform organisms in any ten milliliter (10 ml) portion of a sample when the multi-tube fermentation technique is used or more than one (1) coliform per fifty milliliters (50 ml) when the membrane filter test is used; or
- (c) Two (2) of any ten (10) consecutive samples show a positive test for coliform organisms in any of the ten milliliter (10 ml) portions of a sample when the multi-tube fermentation technique is used or more than one (1) coliform per fifty milliliters (50 ml) when the membrane filter test is used; or
- (d) When performing diarrheal/*Cryptosporidium* decontamination in aquatic venues, the maximum allowable cyanuric acid concentration shall be 15 ppm.

407 RECIRCULATION AND TREATMENT SYSTEM – CROSS-CONNECTION PREVENTION

- 407.1 An atmospheric break or approved back flow prevention device shall be provided in each pool water supply line that is connected to a public water supply.
- 407.2 Vacuum breakers shall be installed on all hose bibbs.
- 408 RECIRCULATION AND TREATMENT SYSTEM — SPA POOL AND SAUNA TURNOVER RATES, & PLUMBING SYSTEM***
- 408.1 The pool recirculation system shall be operated at all times when the pool is open for use. The recirculation system may be shut off three (3) hours after the pool closes and shall be turned back on three (3) hours before opening the pool. Shut down time shall be controlled by a time clock.
- 408.2 Recirculation and treatment equipment such as filters, recessed automatic surface skimmers, water ionizers, ozone generators, disinfection feeders and chlorine generators shall be tested and approved using the NSF/ANSI Standard 50-2007, Circulation System Components and Related Materials for Swimming Pool and Spas/Hot Tubs.
- 408.3 The recirculation system shall be designed to provide a minimum of four (4) turnovers of the pool volume per day. Pools that are less than one thousand square feet (1000 sq. ft.) shall be required to provide eight (8) turnovers per day.
- 408.4 The design pattern of recirculation flow shall be one hundred percent (100%) through the main drain piping and one hundred percent (100%) through the perimeter overflow or sixty percent (60%) through the skimmer system.
- 408.5 All swimming pools including wading pools and spa pools that are open to the public and that are built without a main drain collector tank shall be retrofitted with a properly sized and piped collector tank to eliminate direct suction through the main drain.
- 408.6 All existing public swimming pools with direct suction shall install a main drain cover that meets the ANSI/ASME A112.19.8-2007 standard for drain covers.
- 408.7 Public pools and spas with a single main drain (other than an unblockable drain) shall be equipped with a device or system such as a safety vacuum release system to prevent entrapment.
- 408.8 Public pools and spas that are not in operation do not need to meet the requirements specified in sections 408.5 and 408.6 until they resume operations.
- 408.9 A construction permit shall be obtained from the Department of Consumer and Regulatory Affairs prior to installation of a collector tank.

- 408.10 Any pool that cannot be retrofitted as required in Subsections 408.5 and 408.6 shall be closed.
- 408.11 Newly constructed swimming pools and spas built after the effective date of these regulations shall be built with either:
- (a) More than one (1) drain;
 - (b) One (1) or more unblockable drains; or
 - (c) No main drain.
- 408.12 Hot water facilities shall be disinfected with automatic chemical feed equipment as specified in Subsection 607.3 of these regulations.
- 408.13 The turnover rate shall not exceed thirty (30) minutes.
- 408.14 The whirlpool shall be designed and the hydraulic analysis calculated to provide a thirty (30)-minute turnover rate when the filter is at maximum pressure and ready to be cleaned or backwashed.
- 408.15 The filter shall be cleaned or backwashed when the filter pressure and the flow meter indicate it is necessary.
- 408.16 The plumbing system shall be designed to preclude entrapment in main drains.
- 408.17 Return fitting(s) shall be provided and arranged to facilitate a uniform circulation of water and maintain a uniform sanitizer residual throughout the entire spa or exercise spa.
- 408.18 Suction fittings shall be sized and installed in accordance with the manufacturer's specifications. Spas and exercise spas shall not be used or operated if the suction outlet cover is missing, damaged, broken or loose.
- 408.19 Submerged vacuum fittings shall be prohibited.
- 409 CIRCULATION SYSTEMS – PUBLIC SWIMMING POOLS, TURNOVER RATES***
- 409.1 Circulation systems for pools shall comply with Section 311 of the 2012 International Swimming Pool and Spa Code (ISPSC) and this section.
- 409.2 Circulation equipment shall be sized to turn over the entire water capacity of the pool as specified in Table 407.2 of the 2012 International Swimming Pool and Spa Code (ISPSC). The system shall be designed to provide the required turnover

rate based on the maximum pressure and flow rate recommended by the manufacturer for the filter and clean filter media.

**TABLE 407.2
TURNOVER RATE**

| Swimming Pool Category | Turnover rate In hours |
|-------------------------|---|
| Class A, B, and C pools | Hours equal 1-1/2 times the average depth of pool in feet not to exceed 6 hours |
| Wading pools | 1 |

410 CIRCULATION SYSTEM – AQUATIC RECREATION FACILITIES’ TURNOVER RATES, AND SKIMMING SYSTEMS*

410.1 A circulation system consisting of pumps, piping, return inlets and suction outlets, filters, and other necessary equipment shall be provided for complete circulation of water within the swimming pool, spa pool, or sauna.

410.2 Circulation system equipment shall be designed to turnover one hundred percent (100%) of the nominal pool water volume in the amount of time specified in Table 604.2 of the 2012 International Swimming Pool and Spa Code (ISPSC). The system shall be designed to give the required turnover time based on the manufacturer’s recommended maximum pressure and flow of the filter in clean media condition.

**TABLE 604.2
TURNOVER TIME**

| CLASS OF POOL | MAXIMUM TURNOVER TIME ^a (hours) |
|---|--|
| D-1 | 2 |
| D-2 with less than 24 inches water depth | 1 |
| D-2 with 24 inches or greater water depth | 2 |
| D-3 | 1 |
| D-4 | 2 |
| D-5 | 1 |
| D-6 | 1 |

^a Pools with a sand bottom require a one (1) hour turnover time.

410.3 Circulation systems shall circulate treated and filtered water for twenty-four (24) hours a day.

410.4 The circulation rate shall be permitted to be reduced during periods that the pool is closed to the public, provided that acceptable water clarity conditions are met

prior to reopening the pool for public use. At no time shall the circulation rate be zero.

410.5 Surface skimming systems shall be in accordance with Table 604.3 of the 2012 International Swimming Pool and Spa Code (ISPSC).

**TABLE 604.3
SURFACE SKIMMING SYSTEMS**

| CLASS OF POOL | SURFACE SKIMMING SYSTEM |
|---------------|---|
| D-1 | Zero-depth trench located at static water level or other skimming systems |
| D-2 | Auto skimmer, zero depth trench or gutters |
| D-3 | Auto skimmer, zero depth trench or perimeter device |
| D-4 | Single or multiple skimmer devices for skimming flow |
| D-5 | Skimmers prohibited in side area |
| D-6 | Auto skimmer, zero depth trench, or gutter |

410.6 The installation of skimmers in the side areas of D-5 pools is prohibited.

411 WATER SUPPLY AND WASTEWATER DISPOSAL – CONTAMINANTS, REMOVAL

411.1 No direct mechanical connection shall be made between the potable water supply and the swimming pool or spa, chlorinating equipment, or the system of piping for the swimming pool or spa, unless it is protected against backflow and back-siphonage.

411.2 Backwash water or drainage waters of a swimming pool or spa shall be discharged into a sanitary sewer through an approved air gap, or by other means approved by the District Government.

411.3 When necessary, filter backwash water and drainage water shall be treated chemically or through the use of settling tanks to eliminate or neutralize chemicals, diatomaceous earth, and contaminants in the water that exceeds the limits set by the District Government.

412 REPORTING REQUIREMENTS – DAILY WATER QUALITY & SAFETY LOGS

412.1 Each swimming pool, spa pool, or sauna shall record the following information on a daily basis, unless otherwise required:

- (a) Name of each swimming pool or spa operator on duty;

- (b) Name of each lifeguard on duty;
- (c) Rate of flow readings;
- (d) Weather;
- (e) Temperature;
- (f) Attendance;
- (g) The time of filter backwash or cleaning;
- (h) Injuries or accidents at the swimming pool or spa;
- (i) Chemicals added to the waters;
- (j) Malfunctioning or broken equipment;
- (k) pH readings, taken at a minimum of three (3) hour intervals;
- (l) Free chlorine residual readings, taken at a minimum of three (3) hour intervals;
- (m) Total bromine residual readings, taken at a minimum of three (3) hour intervals; and
- (n) Cyanuric acid, if used, residual readings, taken prior to opening the swimming pool or spa for bathers.

412.2 The information required in Subsection 412.1 shall be recorded a minimum of three (3) times per day, unless otherwise required, and in conformance with the following schedule:

- (a) The first recording of the day shall be made prior to opening the swimming pool or spa opens to bathers;
- (b) The second recording shall be completed between 12 p.m. and 2 p.m.; and
- (c) The final recording shall be completed two (2) hours before closing.

412.3 The Department may require more frequent recordings than those specified in this section if conditions, including high bather load, high temperatures, bright sunlight, or inadequate water quality exist.

- 412.4 The daily operational log must be easily readable, dated and signed, and available on the premises for inspection by the Department for a minimum of three (3) years.
- 412.5 Pool owners, pool and spa operators, and lifeguards shall be responsible for maintaining the daily report logs required in Subsection 412.1.
- 412.6 Complete reports shall reflect manually conducted pool water tests for pH and disinfectant levels at least as specified in Subsections 412.1(i), (k), (l), (m), and (n).
- 412.7 Pool owners, pool and spa operators, or lifeguards shall comply with Standard Operating Procedures for accidents involving bodily fluid as specified in Sections 6.0.1.8, 6.0.1.9, 6.1.2.1.4.1, 6.1.2.1.4.5, 6.1.2.1.4.14, 6.1.2.1.4.15, 6.4.1.1.2(4), 6.4.1.3.1(15), 6.4.1.8, and 6.5 of The Model Aquatic Health Code 2nd Edition (July 2016).

413 REPORTING REQUIREMENTS – EMERGENCY NOTIFICATIONS

- 413.1 A pool owner, pool and spa operator, lifeguard, or swimming instructor shall report any death, serious injury, or injury that requires resuscitation or admission to a hospital occurring at a swimming pool, spa pool, sauna to the Department within twenty-four hours (24 hrs.) of the incident.
- 413.2 A pool owner, pool and spa operator, lifeguard, or swimming instructor shall report a complaint of illness attributed by a bather to use of a swimming pool, spa pool, or sauna to the Department within twenty-four (24) hours of the incident.
- 413.3 The report to the Department shall include the following:
- (a) Name and telephone number or address of the person injured or making a complaint;
 - (b) Date of the incident or onset of illness;
 - (c) Description of the type of injury or complaint;
 - (d) Name and telephone number of the person rendering assistance or first aid;
 - (e) The name of any known hospital, rescue squad or physician providing medical assistance;
 - (f) Names and telephone numbers of available witnesses to the incident; and
 - (g) All physical security breaches.

**CHAPTER 5 EQUIPMENT, EQUIPMENT ROOM, STORAGE AND
MAINTENANCE, AND SAFETY****500 EQUIPMENT ROOMS – SECURITY ACCESS***

- 500.1 Equipment designated by the manufacturer for outdoor use may be located in an equipment area. All other equipment shall be located in an equipment room.
- 500.2 Plastic pipe subject to a period of prolonged sunlight exposure area shall be surrounded with a fence at least four feet (4 ft.) high on all sides and not confined by a building or equivalent structure.
- 500.3 A self-closing and self-latching gate with a locking device shall be provided, if necessary for access.
- 500.4 An equipment room shall be protected on at least three (3) sides and overhead. The fourth side may be a gate, fence, or open if otherwise protected from unauthorized access.
- 500.5 An equipment room shall be lockable or otherwise protected from unauthorized access.
- 500.6 Security access shall be installed on all pool equipment rooms for those that do not presently have a similar level of security.

501 EQUIPMENT ROOMS – FLOOR COVERING*

- 501.1 The equipment room floor shall be of concrete or other nonabsorbent material having a smooth slip resistant finish and shall have positive drainage, including a sump pump if necessary.
- 501.2 Ancillary equipment, such as a heater, shall be stored in an equipment room as specified in Subsection 500.1.

502 EQUIPMENT ROOMS – VENTILATION AND ACCESS*

- 502.1 Equipment rooms shall have either forced draft or cross ventilation.
- 502.2 All below grade equipment rooms shall have a stairway access with forced draft ventilation or a fully louvered door and louvered vent on at least one other side.
- 502.3 Where stairway access is not necessary to carry heavy items into the below grade room or vault, a “ship’s ladder” may be used if approved by the Department.

- 502.4 The opening to an equipment room shall be a minimum of three feet by six feet (3 ft. x 6 ft.) and shall provide easy access to the equipment.
- 502.5 A hose bibb with vacuum breaker shall be located in the equipment room.
- 502.6 A carbon monoxide detector with local alarming, listed and labeled in accordance with UL Standard 2075, shall be installed in all equipment rooms and rooms adjacent to spaces containing fuel-burning equipment or vents carrying the products of combustion.
- 503 EQUIPMENT AND EQUIPMENT ROOMS — SIZE, LIGHTING, MAINTENANCE AND GOOD REPAIR, & PROHIBITED ITEMS***
- 503.1 All equipment and appurtenances shall be kept in good repair.
- 503.2 Skimmers and returns shall be adjustable and functioning.
- 503.3 Filter and pump rooms shall be kept clean and reasonably dry at all times.
- 503.4 Decks, coping, and fencing shall be in good condition.
- 503.5 Guard chairs, rails, ladders, steps, ADA deck-mounted equipment, and diving equipment shall be firmly secured to its base in accordance with Table 4.5.5.7 and Figure 4.5.5.7.1 of the 2nd Edition of the Aquatic Model Health Code.

**TABLE 4.5.5.7
STAIR HANDRAIL DIMENSIONS**

| Dimensions | T-1 | H-1 |
|------------|----------------------|-------------------------|
| Minimum | 3 inches (7.6 cm) | 3.4 inches (86.4 cm) |
| Maximum | N/A | 38 inches (96.5 cm) |

FIGURE 4.5.5.7.1

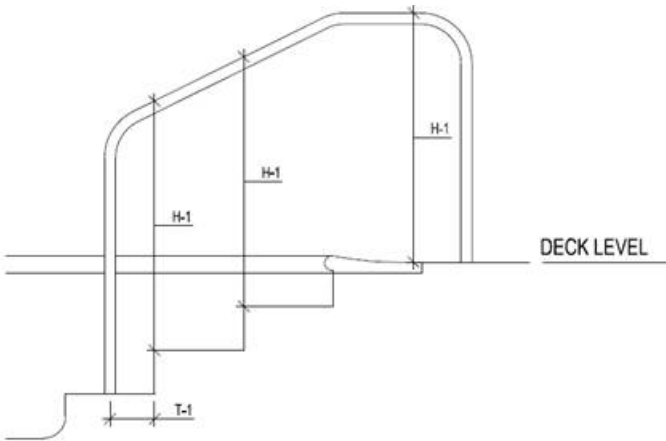

- 503.6 The pool and pool deck shall be kept free from sediment, floating debris, visible dirt and algae. Pools shall be refinished when the pool surfaces cannot be maintained in a safe and sanitary condition.
- 503.7 The pool water level shall be maintained at an elevation suitable for continuous skimming without flooding during periods of non-use.
- 503.8 Face plates and main grates shall be intact, in place, and secured so that they cannot be removed without the use of tools.
- 503.9 Hose bibbs shall be in functioning order and vacuum breakers shall be on all hose bibbs.
- 503.10 Weirs shall be present and functioning.
- 503.11 Scum gutters shall be free flowing.
- 503.12 The room housing the swimming pool or spa shall contain adequate ceiling intake vents and shall be exhausted at floor level.
- 503.13 All other facilities and equipment shall be operable and in good condition.
- 503.14 The size of an equipment room shall provide working space to perform routine operations.
- 503.15 Clearance shall be provided for all equipment as prescribed by the manufacturer to allow normal maintenance operation and removal without disturbing other piping or equipment.

- 503.16 In rooms with fixed ceilings, the minimum ceiling height shall be eight feet (8 ft.).
- 503.17 Equipment rooms shall be lighted to provide thirty foot (30 ft.) candles of illumination at floor level.
- 503.18 Equipment rooms shall not be used to store chemical emitting corrosive fumes, and shall be clear of unnecessary or discarded items.
- 503.19 All chemical tubing that runs through areas where staff works shall be routed in PVC piping to support the tubing and to prevent the supported tubing from leaking.

504 GENERAL AND EMERGENCY POOL LIGHTING REQUIREMENTS

- 504.1 When a swimming pool, spa pool, or sauna is open during periods of low natural illumination, artificial lighting shall be provided so that all areas of the pool, including the bottom main drains are visible.
- 504.2 Overhead or underwater lighting shall be provided to illuminate the pool and adjacent deck areas. Such lighting shall be installed in accordance with the National Fire Protection Association (NFPA 70) National Electrical Code (2014), as specified in Subsection 102.1(1)(7).
- 504.3 For outdoor pools, overhead lighting shall provide not less than three (3) foot-candles of illumination at the pool water surface and on adjacent deck areas. For indoor pools, overhead lighting shall provide not less than ten (10) foot-candles of illumination at the pool water surface.
- 504.4 Underwater lighting shall provide a minimum of eight (8) lumens per square foot of pool water surface area, except when overhead lighting provides not less than fifteen (15) foot-candles of illumination at the pool surface.
- 504.5 Aquatic facilities that operate during periods of low illumination shall be provided with sufficient emergency lighting to permit evacuation of the pool and to secure the area in the event of power failure. The emergency lighting intensity shall not be less than half ($\frac{1}{2}$) foot-candle.
- 504.6 Branch circuits that supply underwater lights operating at more than the Low Voltage Contact Limit as defined in NEC 680.2 shall be Ground-Fault Circuit Interrupter (GFCI) protected.

505 FIRST AID AND SAFETY EQUIPMENT

- 505.1 Safety equipment shall be mounted in a conspicuous place and be readily available for use.

505.2 All public and semi-public swimming pools shall be provided with the following first aid safety equipment that is quickly accessible:

- (a) Automated External Defibrillators (AEDs) shall be located:
 - (1) On the deck near the pool's perimeter; or
 - (2) Inside the facility in a room that cannot be locked.
- (b) A shepherd's hook securely attached to a one (1) piece pole not less than sixteen feet (16 ft.) in length;
- (c) A minimum of one-fourth ($\frac{1}{4}$) inch diameter throwing rope as long as one and one-half ($1\frac{1}{2}$) times the maximum width of the pool or fifty feet (50 ft.), whichever is less, attached to a U.S. Coast Guard approved ring buoy. A rescue-tube shall be accepted as a substitute for the ring buoy where it is accompanied by a lifeguard who has been trained to use it properly;
- (d) First aid supplies consisting of:
 - (1) Splints;
 - (2) One (1) roll of $\frac{1}{2}$ inch adhesive tape;
 - (3) Five (5) four inch by four inch (4 in. x 4 in.) gauze pads;
 - (4) Five (5) two inch by two inch (2 in. x 2 in.) gauze pads;
 - (5) Twenty-five (25) one inch (1 in.) Band-Aids;
 - (6) Two (2) one inch (1 in.) roller bandages;
 - (7) Tape tongue depressors;
 - (8) Two (2) eye pads;
 - (9) One (1) Triangular bandage;
 - (10) Two (2) bee sting swab kits;
 - (11) One (1) elastic bandage;
 - (12) One bag instant ice packs or ice Bag with readily available ice;

- (13) One (1) bottle of eyewash;
 - (14) One (1) container of liquid soap;
 - (15) One (1) facemask for cardiopulmonary resuscitation (CPR) with one-way valve;
 - (16) One (1) pair of scissors;
 - (17) Safety pins;
 - (18) Single-use, sterilized tweezers; and
 - (19) Disposable gloves;
- (e) Two (2) cots or equivalent and two (2) blankets for emergency use only;
 - (f) A backboard with properly spaced handholds, head immobilizer, and proper straps to secure the victim;
 - (g) A blood borne pathogen control kit;
 - (h) A rescue tube designed for lifesaving for each required lifeguard;
 - (i) A hard-wired, non-cordless telephone available to individuals using a pool or spa that:
 - (1) Can directly reach a 911 emergency service without the use of a coin and without connection to an internal switchboard unless the internal switchboard is monitored at all times;
 - (2) Is posted with the 911 emergency number and the name and location of the pool or spa; and
 - (3) Is located within the pool enclosure or in an immediately adjacent room, which cannot be locked.
- 505.3 Pools greater than fifty feet (50 ft.) in length shall have multiple first aid safety equipment with at least one (1) shepherd's hook and one (1) lifesaving ring located along each of the longer sides of the pools.
- 505.4 All pools with a slope transition shall have a safety line. The safety line shall be in place at all times unless a lifeguard or swimming instructor is present.
- 505.5 Pool safety covers required in Subsection 610.10, shall be installed in a track, rail, guides, or secured to the deck, and shall provide a continuous union with the deck,

with no passage. In the case of a pool with a width or diameter greater than eight (8) feet (2.4 m) from the periphery, the cover should be able to hold a weight of four hundred and eighty-five (485) pounds (220.0 kg). If the pool width or diameter is less than eight (8) feet (2.4 m) the cover should hold a weight of two hundred and seventy-five (275) pounds (125 kg).

CHAPTER 6 PLUMBING SYSTEMS, PHYSICAL STRUCTURE, DESIGN, ACCOMODATIONS, FACILITY MAINTENANCE, AND PEST CONTROL

600 PHYSICAL STRUCTURE — BUILDING MATERIALS AND WORKMANSHIP

600.1 The licensee of a newly constructed, remodeled or renovated swimming pool, spa pool, or sauna shall ensure that the design, construction, building materials, and workmanship complies with the most recent version of the District's Construction Codes Supplements, as specified in Subsection 102.1(l) of this chapter, or later construction codes.

600.2 The licensee of an existing swimming pool, spa pool, or sauna shall maintain the facility in good condition by repairing or replacing structural or design defects, operating systems, or fixtures in use before the effective date of these regulations in accordance with the most recent version of the District's Construction Codes Supplements, as specified in Subsection 102.1(l) of this chapter.

600.3 At least thirty (30) days before beginning construction or remodeling of a swimming pool, spa pool, or sauna, the licensee shall submit construction plans with all schedules, including but not limited to floor plans, elevations, and electrical schematics, to the Department for review and approval, as specified in Sections 706 and 707.2.

601 PLUMBING SYSTEMS — DESIGN, CONSTRUCTION, INSTALLATION, AND CLEANABLE FIXTURES*

601.1 All plumbing systems and hoses that convey water shall be designed, constructed, installed and repaired with approved materials in accordance with the International Plumbing Code (2012 edition), Subtitle F (Plumbing Code Supplement of 2013) of Title 12 of the District of Columbia Municipal Regulations.

601.2 All toilet facilities shall be easily cleanable.^N

602 PLUMBING SYSTEMS — WATER TEMPERATURE & FLOW, NUMBERS, AND PROHIBITION*

- 602.1 Toilet facilities located on the premises of an aquatic facility shall be deemed conveniently located and accessible to staff; except, toilet facilities located outside of an aquatic facility do not meet this requirement.
- 602.2 All handwashing sinks in multiple-stall toilet rooms and single-stall toilet rooms shall be equipped to provide water at a temperature of at least one hundred degrees Fahrenheit (100° F) (thirty-eight degrees Celsius (38°C)) through a mixing valve, a combination faucet, or tempered water and a single faucet.
- 602.3 A steam mixing valve shall not be used at a handwashing sink.
- 602.4 A self-closing, slow-closing, or metering faucet shall provide a flow of water for at least fifteen (15) seconds without the need to reactivate the faucet.
- 602.5 Automatic handwashing sinks shall be installed in accordance with the manufacturer's instructions.
- 602.6 Each showerhead shall have a water flow of not less than two gallons per minute (2 gpm) or seven point six one liter per minute (7.61 l/min).
- 602.7 The water temperature at each showerhead shall not exceed one-hundred and ten degrees Fahrenheit (110° F) (forty-three degrees Celsius (43°C)) and shall not be less than ninety degrees Fahrenheit (90° F) (thirty-two degrees Celsius (32°C)).
- 602.8 Where there is heated water provided to showers, the shower water supply shall be controlled by an anti-scald device.
- 602.9 Bathers access to water heaters and thermostatically controlled mixing valves for showers is prohibited.
- 602.10 The number of toilets and urinals shall be based upon the anticipated maximum attendance of bathers and their gender as follows:
- (a) A minimum of one (1) toilet facility (restroom), one (1) toilet stall, and one (1) urinal for the first one hundred (100) male bathers. A minimum of one (1) additional toilet facility, one (1) toilet stall, and one (1) urinal for each additional two (2) hundred male bathers or major fraction thereof; and
 - (b) A minimum of two (2) toilet facilities and two (2) toilet stalls for the first one hundred (100) female bathers. A minimum of one (1) additional toilet facility and one (1) toilet stall for each additional one hundred (100) female bathers or major fraction thereof.
- 602.11 All swimming pools and spas shall have at a minimum the following number of shower facilities:

- (a) One (1) shower for female bathers;
- (b) One (1) shower for male bathers; and
- (c) A minimum of two (2) shower heads for each sex. A minimum of one (1) additional shower head shall be required for each sex, and for each additional fifty (50) male or female bathers.

602.12 There shall be not less than one (1) shower and not greater than half ($\frac{1}{2}$) of the total number of showers required by Subsection 602.11 shall be located on the deck or at the entrance of each pool.

602.13 Shower facilities and dressing rooms shall be provided at all swimming pools unless these facilities are provided in the building housing the swimming pool, spa pool, or sauna.

602.14 Subsection 602.13 does not apply to semi-public swimming pools at hotels, motels, condominiums, and apartments where the:

- (a) Pool's use is restricted to residents and guests; and
- (b) Farthest unit in the hotel, motel, condominium, or apartment is less than three hundred feet (300 ft.) from the pool area, as measured along walkways provided for access by residents and guests to the pool area.

603 TOILET FACILITIES – REQUIRED SIGNAGE

603.1 All single-stall toilet rooms shall display gender-neutral signs on the door that read “Restroom,” or have a universally recognized picture/symbol indicating that persons of any gender may use each restroom, in accordance with Section 301(c) of the Human Rights Act of 1977, effective December 13, 1977 (D.C. Law 2-38; D.C. Official Code §§ 2-1401.01 *et seq.* (2012 Repl.)); and Section 802 of Chapter 8 (Compliance Rules and Regulations Regarding Gender Identity or Expression), Title 4 (Human Rights and Relations), of the District of Columbia Municipal Regulations (DCMR).

603.2 Aquatic facilities employing:

- (a) A staff of five (5) or less may provide a single toilet facility with a gender-neutral sign on the door in accordance with the D.C. Human Rights Act of 1977, effective December 13, 1977, as amended (D.C. Law 2-38; D.C. Official Code §§ 2-1401.01 *et seq.* (2012 Repl.)); or
- (b) A staff of five (5) or more shall have multiple toilet facilities that are either:

- (1) Single-stall toilet rooms with a gender-neutral sign on each door as specified in Subsection 3101.2 in accordance with the D.C. Human Rights Act of 1977, effective December 13, 1977, as amended (D.C. Law 2-38; D.C. Official Code §§ 2-1401.01 *et seq.* (2012 Repl.)); or
- (2) Multiple-stall toilet rooms with gender-specific signs on the doors that read “Men” and “Women” or contain gender-specific, universally recognized pictorials of “Men” and “Women”.

603.3 Facilities which have multiple-stall toilet rooms with gender-specific signs on the doors shall allow individuals the right to use the gender-specific toilet room that is consistent with their gender identity or expression pursuant to 4 DCMR § 802.1.

604 SHOWER FACILITIES, DRESSING ROOMS — REASONABLE ACCOMODATIONS

604.1 All shower facilities shall be constructed and designed for individual privacy enclosures in accordance with Section 301(c) of the Human Rights Act of 1977, effective December 13, 1977 (D.C. Law 2-38; D.C. Official Code §§ 2-1401.01 *et seq.* (2012 Repl.)); and Sections 804 and 805 of Chapter 8 (Compliance Rules and Regulations Regarding Gender Identity or Expression), Title 4 (Human Rights and Relations) DCMR.

604.2 Facilities shall make reasonable accommodations to allow an individual access to and the use of the facility that is consistent with that individual's gender identity or expression pursuant to 4 DCMR § 805.1.

605 FACILITY MAINTENANCE — PHYSICAL STRUCTURE, MATERIALS, CLEANABILITY, AND PROHIBITION

605.1 Toilet room floors shall be constructed of sealed concrete or other nonabsorbent materials with a smooth, slip-resistant surface to insure thorough cleaning.

605.2 The intersection of floors, walls, panels, stalls, or barriers shall be covered or sealed with waterproof materials.

605.3 Walls, panels, stalls, or barriers between toilet facilities, shower facilities, and dressing rooms, shall be made of durable materials not subject to water damage, and shall be designed so that a waterway is provided between the wall, panel, stall, barrier and the floor to permit thorough cleaning of the wall, panel, stall, barrier and floor areas with hoses and brooms.

605.4 Dressing room floors shall be made of the durable materials, not subject to water damage throughout.

- 605.5 Floor drains shall be provided, and floors shall be sloped not less than $\frac{1}{4}$ inch per foot toward the drains to ensure positive drainage.
- 605.6 Carpets, duckboards and footbaths are prohibited in toilet facilities, shower facilities, and dressing rooms.
- 606 FACILITY MAINTENANCE — TOILET FACILITIES (RESTROOMS), SHOWER FACILITIES, DRESSING ROOMS, HANDWASHING SINKS, ACCESS, AND PROHIBITIONS***
- 606.1 Each aquatic facility's plumbing systems, including but not limited to toilet facilities (restrooms), shower facilities, and handwashing sinks shall be maintained in good repair at all times.
- 606.2 Each licensee shall provide sufficient toilet facilities (restrooms) that are:
- (a) Kept in clean and sanitary conditions, free of solid waste, and litter; and
 - (b) Enclosed with tight-fitting, self-closing doors or locking doors.
- 606.3 Toilet facility (restroom) doors shall be kept closed except during cleaning and maintenance operations.
- 606.4 At no time shall consumers or staff enter toilet facilities (restrooms), shower facilities, or dressing rooms during routine cleaning or maintenance emergency.
- 606.5 Each handwashing sink and shower facility shall be conveniently equipped with soap dispensers with either liquid or powdered soap. The dispensing unit shall be made of metal or plastic, glass materials are prohibited.
- 606.6 Liquid or powder soap dispensers shall be provided in each toilet facility (restroom) and shower facility. Reusable cake soap is prohibited.
- 606.7 Mirrors shall be shatter resistant, where provided.
- 606.8 Baby-changing tables shall be provided in toilet facilities (restrooms) having two (2) or more toilet stalls.
- 606.9 A hose bibb with vacuum breaker shall be provided in or within fifty feet (50 ft.) of each toilet facility (restroom) to allow for ease of cleaning.
- 606.10 Toilet paper holder, a supply of toilet tissue, and a waste receptacle shall be provided in each stall of a multiple-stall toilet room, and in every single-stall toilet room. A covered waste receptacle for feminine hygienic products shall be provided in each toilet stall designated for female staff and/or bathers.

- 606.11 Feminine hygiene products shall be supplied in dispensing units installed in toilet facilities (restrooms) and shower areas designated for female staff and/or bathers.
- 607 FACILITY MAINTENANCE – EQUIPMENT, CHEMICAL SUPPLIES, USE, LABELING, AND ACCESS***
- 607.1 Filter and pump rooms shall be kept clean and reasonably dry at all times.
- 607.2 Controls, valves, and gauges shall be accessible and shall not be blocked by extraneous materials. Valves and gauges shall function properly and be labeled in accordance with a posted backwash procedures chart.
- 607.3 Disinfectant and chemical feeders, capable of precisely introducing a sufficient quantity of an approved disinfecting agent to maintain the appropriate disinfectant residuals, shall be used at swimming pools and spa pools.
- 607.4 No person shall use chemical products or pesticides in a manner that is inconsistent with the product’s labeling, or that is in violation of any restrictions imposed on the product’s use by the United States Environmental Protection Agency or the Department.
- 607.5 All chemical products used in swimming pools, spa pools, or sauna waters shall be used in accordance with:
- (a) Sections 2208 and 2209 of the D.C. Pesticide Operations Regulations, effective March 20, 2015 (D.C. Law 2-70; D.C. Official Code §§ 8-401 *et seq.*);
 - (b) Manufacturer’s use directions included in labeling; and
 - (c) The conditions of certification, if certification is required for use of pest control materials.
- 607.6 The Department may approve disinfectant products other than chlorine or bromine that:
- (a) Are labeled with clear directions for its use;
 - (b) Provide satisfactory residual effects that are easily measured;
 - (c) Are as effective as chlorine or bromine; and
 - (d) Do not impart toxic properties into the water that could create a danger to public health or that could create objectionable physiological and environmental effects.

- 607.7 Non-staff persons shall not have unsupervised access to machinery, electric panels, or chemicals used for the swimming pool, spa pool, or sauna.
- 608 FACILITY MAINTENANCE – CHEMICALS, HANDLING, STORAGE, AND SAFETY***
- 608.1 Chemicals shall be labeled and stored in a cool, dry, and well-ventilated area under a roof and the area shall be inaccessible to the public.
- 608.2 Chemicals which emit corrosive fumes shall not be stored in the equipment room as specified in Subsection 503.18.
- 608.3 An aquatic facility's use of compressed chlorine gas is prohibited in:
- (a) Newly constructed facilities; and
 - (b) Existing facilities undergoing any renovations or retrofitting that require DCRA to issue a Building Permit.
- 608.4 The Department shall prohibit a facility from using chlorine gas if the Department determines through an inspection (preoperational, routine or complaint) that safety equipment and/ or training requirements cannot be met as required by the manufacturer, or as directed by the Department.
- 608.5 A licensee shall ensure chlorine gas equipment and containers are:
- (a) Located out of direct sunlight;
 - (b) Chained or fastened in place to prevent tipping;
 - (c) Equipped with a shut-off wrench when in use; and
 - (d) The installed power exhaust system of such equipment operates properly and that a bottle of ammonia is available to test for leaks.
- 608.6 Empty chemical containers shall be stored and disposed of in such a manner that they are not accessible to the public.
- 608.7 Solutions and dry chemical spills, waste material, excess water, and debris shall be cleaned and removed promptly.
- 608.8 Safety Data Sheets (SDS) for all potentially hazardous chemicals shall be provided to the aquatic facility's pool and spa operator by the licensee or Pool Management Company.

- 608.9 All chemicals shall be handled, used, stored, and disposed of in accordance with the Safety Data Sheets, all applicable federal and District laws, and Sections 607.3, 607.4, 607.5, 607.6, 607.7, and Section 608.
- 608.10 All chemicals shall be stored in an area that has:
- (a) Protection against weather, excess heat and moisture;
 - (b) A lockable door;
 - (c) Continuous ventilation sized at a minimum of two cubic feet per minute (2 cfm) per square foot of floor area and exhausts to the open air;
 - (d) A minimum of thirty (30) foot-candles (323 lux) of illumination to allow operators to read labels on containers throughout the chemical storage area and pump room;
 - (e) Adequate room to separate potentially reactive chemicals;
 - (f) Storage and or filter room door permanently labeled:
“DANGER – CHEMICAL STORAGE AREA – DO NOT ENTER”
 - (g) Safety Data Sheets posted; and
 - (h) Availability of personal safety gear for all chemicals on site as required by the Safety Data Sheets (SDS), including:
 - (1) Goggles for eye protection;
 - (2) Splash-guard aprons;
 - (3) Neoprene gloves or other gloves as specified in the Safety Data Sheets;
 - (4) Respirators that are required by the Safety Data Sheets; and
 - (5) Proper training for handling procedures, which are posted in the filter room and chemical storage areas.

609 FACILITY MAINTENANCE – EYE WASH STATIONS, INSTALLATION, ACCESSIBILITY, MAINTENANCE, AND TRAINING

- 609.1 Eye wash stations capable of delivering low-pressure tepid potable water to both eyes simultaneously for at least ten (10) minutes shall be installed in all chemical storage rooms and work areas with corrosive substances.

- 609.2 Eye wash stations shall:
- (a) Be located within a ten (10) second walking distance in the installed area with a path that is free of obstructions, without having to pass through any doors;
 - (b) Use potable water and shall be equipped with stay-open valves that are easy to find and use and that remain open until manually closed;
 - (c) Well-lit, with signs that are easily identifiable and highly visible;
 - (d) Be directly plumbed; and
 - (e) Be inspected on a weekly basis and documented in a log book to ensure proper maintenance and working condition.

609.3 Licensees, pool and spa operators, lifeguards, and swimming instructors are required to know where the eye wash stations are located and are trained on how to use them in the event of an emergency.

610 FACILITY MAINTENANCE – EFFECTIVE BARRIERS, FENCES*

610.1 All outdoor public swimming pools and spa pools shall be surrounded by a minimum seventy-two inch (72 in.) high fence or other substantial barrier approved by the Department.

610.2 The fence shall be continuous around the perimeter of the pool area that is not otherwise blocked or obstructed by adjacent buildings or structures and shall adjoin with itself or abut to the adjacent members.

610.3 All aquatic venues shall be through self-closing, self-latching lockable gates in which the self-latching mechanisms shall be located not less than four and a half feet (4½ ft.) (1.4 m) above finished grade.

610.4 Door access points from public rooms such as lobbies or club houses need not be through gates.

610.5 Gates shall open outward away from the pool area.

610.6 A latched, lockable gate shall be placed in the fence within ten feet (10 ft.) of the equipment area for service access.

610.7 Screened pool enclosures shall be hardened on the bottom three feet (3 ft.)

- 610.8 Fencing consideration shall be given to the U.S. Consumer Product Safety Commission (CPSC) Publication No. 362 Guidelines.
- 610.9 Safety Covers shall meet strict performance standards as set by the American Society for Testing and Materials in ASTM Standard F1346-91, Standard Performance Specification for Safety Covers and Labeling Requirements for All Covers for Swimming Pools, Spas and Hot Tubs.
- 610.10 All public and semi-public pools shall be installed or secured with pool safety covers as specified in Subsection 505.5, during the following occurrence:
- (a) At the end of the outdoor swimming season;
 - (b) An in-door or out-door pool is taken out of service for more than thirty (30) days; or
 - (c) When a pool is experiencing a mechanical failure that prevents proper recirculation of water for more than seventy-two (72) hours.
- 610.11 All standing water shall be substantially drained from the cover with a pump within thirty (30) minutes after cessation of normal rainfall.

611 FACILITY MAINTENANCE — CONTROLLING PESTS*

- 611.1 The presence of insects, rodents, and other pests shall be controlled to minimize their presence on the premises by:
- (a) Routinely inspecting the premises for evidence of pests;^N
 - (b) Using methods, if pests are found, such as trapping devices or other means of pest control, such as covered, tamper-resistant bait stations; and
 - (c) Eliminating harborage conditions.^N
- 611.2 The licensee shall maintain a copy of the establishment's professional service contract and service schedule, which documents the following information:
- (a) Name and address of its D.C. licensed pest exterminator/contractor in accordance with Sections 2300 and 2400 of the D.C. Pesticide Operations Regulations, effective March 20, 2015 (D.C. Law 2-70; D.C. Official Code §§ 8-401 *et seq.*);
 - (b) Frequency of pest extermination services provided under the contract; and
 - (c) Date pest extermination services were last provided to the establishment.

612 FACILITY MAINTENANCE — REMOVING DEAD OR TRAPPED BIRDS, INSECTS, RODENTS, & OTHER PESTS, AND ANIMAL PROHIBITION*

612.1 Dead or trapped birds, insects, rodents, and other pests shall be removed from control devices and the premises at a frequency that prevents their accumulation, decomposition or the attraction of pests.

612.2 Animals shall not be allowed in aquatic facilities.

**CHAPTER 7 APPLICATION & LICENSING REQUIREMENTS,
AND DEFINITIONS**

700 LICENSES, REGISTRATIONS, & CERTIFICATIONS, AND CERTIFICATE OF OCCUPANCY REQUIREMENTS*

700.1 No person shall own, operate, or manage a public swimming pool, spa pool, or sauna without a valid license issued by the Mayor.

700.2 No person shall own, operate, or manage a public swimming pool, spa pool, or sauna with an expired or suspended license issue.

700.3 No person shall operate, or manage a public swimming pool, spa pool, or sauna without a current Certificate of Occupancy.

700.4 No person shall serve as a pool and spa operator without a current Pool and Spa Operator's Registration Card issued by the Department in violation of Subsection 301.4.

700.5 No person shall serve as a lifeguard or swimming instructor without a current lifeguard or instructor certification issued by the American Red Cross or the YMCA, or other nationally recognized aquatic training organizations adopted and recognized by the D.C. Department of Health in violation of Subsections 302.3 and 302.4.

700.6 No person shall serve as a lifeguard or swimming instructor without a current certification in First Aid, and in adult, child and infant Cardio-Pulmonary Resuscitation and Automated External Defibrillator (CPR/AED) issued by the American Red Cross, the American Heart Association, the National Safety Council, the American Academy of Orthopedic Surgeons, or other nationally recognized aquatic training organization adopted and recognized by the D.C. Department of Health in violation of Subsection 302.4.

700.7 No person shall construct, install, renovate or retrofit any public swimming pool, spa pool, or sauna without first having received written approval from the Department of Consumer and Regulatory Affairs and the Department of Health.

701 APPLICATION PROCEDURES FOR FACILITY LICENSE – FORM OF SUBMISSION, NOTICE

- 701.1 An applicant shall submit a written application for a swimming pool, spa pool, or sauna on a form provided by the Department.
- 701.2 An applicant shall submit an application to license a newly constructed or newly renovated swimming pool, spa pool, or sauna at least thirty (30) calendar days before the proposed opening date of the swimming pool, spa pool, or sauna.
- 701.3 An applicant shall submit an application to renew a license at least thirty (30) calendar days before the expiration date of the current license for an existing swimming pool, spa pool, or sauna.
- 701.4 A new application shall be filed with the Department within thirty (30) calendar days of any change in ownership or location. An applicant shall also notify the Department immediately if the applicant decides not to open, sell, or transfers the aquatic facility at the location identified in the application.
- 701.5 The Department shall accept completed plans and specifications approved by the Department of Consumer and Regulatory Affairs that meet the requirements of these regulations, and shall report its findings to the applicant within thirty (30) calendar days of the date the completed plans are received.
- 701.6 Plans and specifications that are not approved as submitted shall be changed to comply with these regulations or shall be returned as disapproved.

702 APPLICATION PROCEDURES FOR FACILITY LICENSE – CONTENT OF THE APPLICATION PACKET

- 702.1 The Department shall not process an application for a new license, license renewal, or change in ownership or location where administrative actions are pending against the licensee of a new or existing aquatic facility.
- 702.2 The Department shall accept completed plans and specifications approved by the Department of Consumer and Regulatory Affairs that meet the requirements of these regulations, and shall report its findings to the applicant or licensee within thirty (30) days of the date the completed plans are received.
- 702.3 The Department application for a public swimming pool, spa pool, or sauna license shall include the name, address, and signature of the applicant, and the following information:
- (a) Name, mailing address and telephone number of the licensee;

- (b) Trade name, if applicable;
- (c) Name and address of corporate officers, if applicable;
- (d) Name and address of registered agent in the District, pursuant to the “District of Columbia Official Code Title 29 (Business Organizations) Enactment Act of 2009”, as amended, effective July 2, 2011 (D.C. Law 18-378; D.C. Official § 29-104.02 (2013 Repl.)), if applicable;
- (e) Address of the swimming pool, spa pool, or sauna facility and hours of operation;
- (f) Type of aquatic facility; and
- (g) Required application fee.

702.4 The following documents shall be submitted with the Department application for review:

- (a) Current Certificate of Occupancy and required approvals issued by DCRA;
- (b) A complete set of construction plans including all schedules, including floor plans, elevations, and electrical schematics, as specified in Section 705;
- (c) Passing Pre-operational Inspection Report for compliance with these Regulations from the Department (no cost for the first Pre-operation Inspection Report);
- (d) Copies of current registrations issued by the Department to the facility’s Pool and Spa Operators, including the individuals’ names, addresses, and cell phone numbers;
- (e) Copies of current lifeguards and swimming instructors’ training certifications and First Aid certifications as specified in Section 302; and
- (f) Copies of the facility’s D.C. licensed Pest Exterminator/Contractor as specified in Subsection 611.2.

703 APPLICATION PROCEDURES – DENIAL OF FACILITY LICENSE, NOTICE

703.1 If an application for a new license or renewal license is denied, the Department shall provide the applicant with written notice that includes:

- (a) The specific reasons and legal authority for denial of the license;
- (b) The actions, if any, that the applicant must take to qualify for a new license or to renew an existing license; and
- (c) Notice of the applicant's or licensee's right to a hearing as prescribed in sections 812.2 and 812.3.

704 ISSUANCE OF POOL AND SPA OPERATORS' REGISTRATION CARDS

704.1 To qualify for a Pool and Spa Operator's Registration Card an applicant shall:

- (a) Complete a registration form provided by the Department of Health;
- (b) Submit proof of certifications specified in Section 300; and
- (c) Pay the required fee.

704.2 A Pool and Spa Operator's Registration Card shall be valid for a three (3) year period, as specified in Subsection 301.4.

705 ISSUANCE OF FACILITY LICENSE — REQUIRED PLAN REVIEWS AND APPROVALS

705.1 The following plans and specifications for a swimming pool, spa pool, or sauna shall be submitted to the Department of Consumer & Regulatory Affairs for review and approval as specified in this section and Subsection 706.1:

- (a) Proposed layout, mechanical schematics, construction materials, and finish schedules;
- (b) Proposed equipment types, manufacturers, model numbers, locations, dimensions, performance capacities, and installation specifications;
- (c) A complete set of elevations and drawings for all custom fabricated equipment; and
- (d) Other information that may be required before the Department of Consumer & Regulatory Affairs may approve proposed plans for the construction, or renovation, or retrofits, including approvals by other District agencies, when necessary.

706 ISSUANCE OF NEW AND RENEWAL FACILITY LICENSES — EXISTING FACILITY, NEW CONSTRUCTION, RENOVATION, AND RETROFITTING OF SWIMMING POOLS, SPA POOLS, OR SAUNAS FACILITIES

706.1 An applicant or licensee shall submit properly prepared plans and specifications to the Department of Health for review and approval, as specified in Section 705, at least thirty (30) calendar days before:

- (a) Opening a new or existing swimming pool, spa pool, or sauna;
- (b) Building a new swimming pool, spa pool, or sauna facility;
- (c) Renovating or retrofitting an existing swimming pool, spa pool, or sauna; or
- (d) Changing the type of swimming pool, spa pool, or sauna facility's operation.

706.2 The Department shall issue an aquatic facility license after an applicant has:

- (a) Submitted a properly completed application provided by the Department;
- (b) Paid all required fees;
- (c) Obtained required approvals of documents specified in Sections 701.5, 701.6, 702.4, and 705; and
- (d) Passed a preoperational inspection required in Subsection 710.1.

707 ISSUANCE OF FACILITY LICENSE — EXISTING FACILITIES, AND CHANGE IN OWNERSHIP, OR LOCATION

707.1 The Department shall renew a license to a swimming pool, spa pool, or sauna facility after a properly completed application is submitted, reviewed and approved, applicable fees are paid, and the Department has determined through an inspection that the facility is in compliance with this Regulation.

707.2 The Department shall issue a new license to a swimming pool, spa pool, or sauna facility that has changed ownership or changed location after a properly completed application is submitted, reviewed and approved, applicable fees are paid, and an inspection shows that the facility is in compliance with this Regulation.

708 REQUIRED POSTINGS

708.1 A public swimming pool, spa pool, or sauna shall provide notice to the Department of its intent to shut down permanently or temporarily at least thirty (30) calendar days before discontinuing operations.

708.2 All licenses, Certificate of Occupancy, certifications, Department posted warnings, and current inspection results shall be conspicuously posted near a public entrance within the swimming pool, spa pool, or sauna facility in accordance with Sections 201, 202, and 901.1(b).

709 LICENSES AND PERMITS NOT TRANSFERABLE

709.1 A facility license or permit to operate a swimming pool, spa pool, or sauna facility shall not be transferred from one person to another person, from one facility to another facility, or from one location to another location even if owned, leased or operated by the same person.

710 ACCESS & INSPECTIONS — DEPARTMENT’S RIGHT OF ENTRY, DENIAL, AND INSPECTORS’ COMPETENCY*

710.1 The Department shall determine an aquatic facility’s compliance with these regulations by conducting the inspections:

- (a) Preoperational and follow-up inspections, as necessary to obtain a new license for indoor or seasonal outdoor swimming pools, spa pools, and saunas.
- (b) For indoor swimming pools, spa pools, and saunas with existing valid licenses:
 - (1) Two (2) unannounced, routine inspections; and
 - (2) Follow-up inspections, as necessary.
- (c) For seasonal outdoor swimming pools, spa pools, and saunas with existing valid licenses:
 - (1) Mandatory preopening inspections. Preopening inspections shall be requested in writing at least thirty (30) days prior to opening;
 - (2) One (1) unannounced, routine inspection; and
 - (3) Follow-up inspections, as necessary.
- (d) Unannounced, complaint-generated inspections.

710.2 After representatives of the Department present official credentials and provide notice of the purpose and intent to conduct an inspection in accordance with these regulations, the applicant, licensee, pool and spa operator, or lifeguard shall allow the Department access to any part, portion, or area of a swimming pool, spa pool, or sauna facility.

- 710.3 The Department may enter and inspect all aspects of a swimming pool, spa pool, or sauna facility, including, but not limited to its physical facilities, operations, equipment, records, chemicals and other operational supplies, at any time for one or more of the following purposes:
- (a) To determine if the swimming pool or spa facility is in compliance with these regulations;
 - (b) To investigate an emergency affecting the public health if the swimming pool or spa is or may be involved in the matter causing the emergency;
 - (c) To investigate, examine and sample water quality and testing for biological contaminants, as specified in Subsection 403.1; or
 - (d) To obtain information, and examine and copy all records on the premises relating to reporting requirements as specified in Section 412.
- 710.4 If a person denies the Department access to any part, portion, or area of a swimming pool, spa pool, or sauna facility, the Department shall inform the individual that:
- (a) The applicant or licensee is required to allow access to the District agencies as specified in Subsections 710.2 and 710.3;
 - (b) If access is denied, an inspection order allowing access may be obtained in accordance with District law; and
 - (c) The Department is making a final request for access.
- 710.5 If the Department presents credentials and provides notice as specified in Subsection 710.2, explains the authority upon which access is requested, and makes a final request for access as specified in Subsection 710.4, and the applicant or licensee continues to refuse access, the Department shall provide details of the denial of access on the inspection report.
- 710.6 If the Department is denied access to a swimming pool or spa facility for an authorized purpose, after complying with Subsection 710.5, the Department may:
- (a) Summarily suspend a license issued to the swimming pool, spa pool or sauna in accordance with Subsection 807.1;
 - (b) Revoke or suspend a license issued to the swimming pool spa pool or sauna facility in accordance with Subsection 812; or

- (c) Request that the Office of the Attorney General for the District of Columbia commence an appropriate civil action in the Superior Court of the District of Columbia to secure a temporary restraining order, a preliminary injunction, a permanent injunction, or other appropriate relief from the court, to enforce these regulations.

710.7 Authorized representatives of the Department who are responsible for conducting inspections, plan reviews, and approvals of aquatic facilities shall be properly trained and certified as specified in Sections 300 and 302 of these regulations.

711 REPORT OF FINDINGS – SPECIFYING TIME FRAME FOR CORRECTIONS

711.1 The Department shall specify on its inspection report the time frame for correction of violations as specified in Sections 717 and 719.

712 REPORT OF FINDINGS – ISSUING REPORT AND OBTAINING ACKNOWLEDGMENT OF RECEIPT

712.1 At the conclusion of an inspection, the Department shall provide a copy of its completed inspection report and the notice to correct violations to the licensee, and request a signed acknowledgment of receipt. The inspection report shall contain a listing of violations by area in the facility's operation and inspection item with corresponding citations to applicable regulatory provisions.

713 REPORT OF FINDINGS – REFUSAL TO SIGN ACKNOWLEDGMENT

713.1 The Department shall inform a person who declines to sign an acknowledgment of receipt of inspection findings that:

- (a) An acknowledgment of receipt is not an agreement with the finding;
- (b) Refusal to sign an acknowledgment of receipt will not affect the licensee's or dealer's obligation to correct the violations noted in the inspection report within the time frames specified; and
- (c) A refusal to sign an acknowledgment of receipt will be noted in the inspection report for the swimming pool, spa pool, or sauna facility.

714 REPORT OF FINDINGS – PUBLIC INFORMATION, RECORDS RETENTION

714.1 The Department shall keep and maintain in-office as an active record a copy of each inspection report, complaint, inspector's sample reports, license suspension, and other correspondence regarding a public swimming pool, spa pool, or sauna facility within the District for a period of one (1) year, and then as an inactive

record for a period of two (2) additional years. Inactive records shall be destroyed in-house at the end of the two (2)-year inactive period.

714.2 In the case of an audit or investigation, the Department shall keep all records until the audit or investigation has been completed.

714.3 The Department shall treat the inspection report as a public document and shall make it available for disclosure to a person who requests it as provided in the District of Columbia Administrative Procedure Act, approved October 21, 1968 (82 Stat. 1204; D.C. Official Code §§ 2-501 *et seq.* (2012 Repl.)).

715 IMMEDIATE HEALTH HAZARDS – CEASING FACILITY OPERATIONS AND EMERGENCY REPORTING*

715.1 The Department shall summarily suspend operations, or, a licensee shall immediately discontinue operations and notify the Department, whenever a swimming pool, spa pool, or sauna facility is operating with any of the following conditions:

- (a) Operating an aquatic facility without a clock in violation of Subsection 202.2;
- (b) Operating an aquatic facility with improper water temperatures in violation of Subsections 202.1(b), and 402.5;
- (c) Operating an aquatic facility with a total absence of or improper depth markings in violation of Subsections 201.1(e), 402.3, and 402.4;
- (d) Operating an aquatic facility with an unapproved or contaminated water supply source for potable water use in violation of Sections 400 and 401;
- (e) Operating an aquatic facility without proper water clarity from the pool deck in violation of Subsections 402.1, 402.2, and 410.1;
- (f) Operating an aquatic facility with water quality pH level below 6.5 in violation of Subsection 404.2(a)(1);
- (g) Operating an aquatic facility with water quality pH level above 8.0 in violation of Subsection 404.2(a)(2);
- (h) The disinfectant level is below the minimum or above the maximum in violation of Subsection 404.2(b);
- (i) Operating an aquatic facility with contaminated water not treated or improperly treated with disinfectants in violation of Sections 406 and 411;

- (j) Failing to continuously operate the aquatic facility's filtration equipment in violation of Sections 408.1, 408.3, 408.12, 409, and 410.3;
- (k) Operating an aquatic facility that is not retrofitted with a properly sized and piped collector tank to eliminate direct suction through the main drain in violation of Subsection 408.5;
- (l) Operating an aquatic facility with direct suction without installing a main drain cover that meets the ANSI/ASME A112.19.8-2007 standard for drain covers in violation of Subsection 408.6;
- (m) Operating an aquatic facility with a single main drain (other than an unblockable drain) without being equipped with a device or system such as a safety vacuum release system to prevent entrapment in violation of Subsection 408.7;
- (n) Operating an aquatic facility in violation of Subsection 408.11;
- (o) Operating an aquatic facility with broken, unsecured, improperly secured, damaged or missing main drain grate or any submerged suction outlet grate in violation of Subsections 408.16 and 408.18;
- (p) Operating an aquatic facility in violation of Sections 500, 501, 502, 503, and 504;
- (q) Operating an aquatic facility without an emergency lighting source, or failing to maintain an emergency lighting source in violation of Subsection 504.5;
- (r) Operating an aquatic facility without required first aid and safety equipment on deck as specified in Section 505;
- (s) Operating an aquatic facility with improper plumbing cross-connections between the drinking water supply and aquatic facility water or between sewage system and the aquatic facility including filter backwash facilities in violation of Subsection 601.1;
- (t) Operating an aquatic facility without hot water in violation of Subsections 602.2 and 602.7;
- (u) Failing to properly handle, use, label, store, or ventilate chemicals in an aquatic facility in violation of Sections 607 or 608;
- (v) Using unapproved chemicals or applying chemicals by unapproved methods to an aquatic facility's water in violation of Subsection 607.3;

- (w) Failing to prevent unauthorized access to an aquatic facility's machinery, electric panels, or chemicals used for the swimming pool, spa pool, or sauna in violation of Subsection 607.7;
- (x) Operating an aquatic facility without the required personal protective equipment (ppe) to handle chemicals in violation of Subsection 608.10(h);
- (y) Operating an aquatic facility with safety covers that do not meet strict performance standards as set by the American Society for Testing and Materials in ASTM Standard F1346-91, Standard Performance Specification for Safety Covers and Labeling Requirements for All Covers for Swimming Pools, Spas and Hot Tubs in violation of Subsection 610.10; or
- (z) Operating an aquatic facility with safety covers that are improperly installed, or secured with continuous union to the deck in violation of Subsection 505.5.

715.2

In addition to the imminent health hazards identified in Subsection 715.1, the Department shall summarily suspend operations if it determines through an inspection, or examination of records or other means as specified in Section 710, the existence of the following conditions, including but not limited to:

- (a) Operating an aquatic facility with a bather load in violation of Subsections 201.1(b), 202.1(d), and 304.1;
- (b) Serving as a lifeguard or swimming instructor without a current lifeguard or instructor certification issued by the American Red Cross, the YMCA, or other nationally recognized aquatic training organizations adopted and recognized by the D.C. Department of Health in violation of Subsections 302.3 and 302.4;
- (c) Serving as a lifeguard or swimming instructor without a current certification in First Aid, and in adult, child and infant Cardio-Pulmonary Resuscitation and Automated External Defibrillator (CPR/AED) issued by the American Red Cross, the American Heart Association, the National Safety Council, the American Academy of Orthopedic Surgeons, or other nationally recognized aquatic training organizations adopted and recognized by the DC Department of Health in violation of Subsections 302.3 and 302.4;
- (d) Operating a swimming pool, spa pool, or sauna without the required number of lifeguards in violation of Section 304;

- (e) Operating an aquatic facility without an approved Child Safety Plan, if applicable, or failing to provide copies of the facility's Child Safety Plan to the Department for review and approval in violation of Section 305;
- (f) Operating an aquatic facility in violation of a Notice of Closure/Summary Suspension, Revocation, Suspension, warnings, or other directives issued by the Department as specified in Sections 408.10, 607.4, 716, 801, 807, 811, and 812;
- (g) Using, selling, moving, or destroying equipment, chemicals, or other operational supplies subject to a Condemnation Order by the Department in violation of Subsection 804.1;
- (h) Operating an aquatic facility without a Water Quality Test Kit in violation of Section 405;
- (i) Operating an aquatic facility without maintaining daily water quality and safety logs in violation of Section 412;
- (j) Failing to report a death, serious injury, or injury that requires resuscitation or admission to a hospital occurring at a swimming pool, spa pool, sauna to the Department within twenty-four hours (24 hrs.) of the incident in violation of Subsection 413.1;
- (k) Failing to report a complaint of illness attributed by a bather to use of a swimming pool, spa pool, or sauna to the Department within twenty-four (24) hours of the incident in violation of Subsection 413.2;
- (l) Owning, operating, or managing a swimming pool, spa pool, or sauna without a valid license issued by the Department in violation of Subsection 700.1;
- (m) Failing to maintain plumbing systems, including but not limited to toilet facilities (restrooms), shower facilities, and handwashing sinks in good repair in violation of Subsection 606.1;
- (n) Using compressed chlorine gas or chlorine gas in violation of Subsections 608.3 and 608.4;
- (o) Owning, operating, or managing a swimming pool, spa pool, or sauna without required barriers and/or fencing; or, with barriers and/or fencing not approved by the Department in violation of Section 610;
- (p) Owning, operating, or managing a swimming pool without a pool safety cover in violation of Subsection 610.10;

- (q) Owning, operating, or managing a swimming pool, spa pool, or sauna with an expired or suspended license issue in violation of Subsection 700.2;
- (r) Operating, or managing a public swimming pool, spa pool, or sauna without a valid Certificate of Occupancy in violation of Subsection 700.3;
- (s) Serving as a pool and spa operator without a current Pool and Spa Operator's Registration Card issued by the Department in violation of Subsection 700.4;
- (t) Constructing, installing, renovating or retrofitting, or operating any public swimming pool, spa pool, or sauna without first having received written approved from the Department of Health and the District Government in violation of Sections 705 and 706;
- (u) Failing to allow the Department access to a swimming pool, spa pool, or sauna in violation of Section 710;
- (v) Failing to post licenses, Certificate of Occupancy, certifications, and current inspection reports in violation of Subsection 708.2;
- (w) Failing to post required signs in violation of Sections 201 and 202;
- (x) Removing required signs or Department posted warnings or closures in violation of Sections 715.3, 720.3, 805.1, and 901.1(b); or
- (y) Operating an aquatic facility with conditions dangerous to the health, safety, or welfare of bathers or patrons at the swimming pool, spa pool, or sauna, including but not limited to:
 - (1) Accidents involving bodily fluids in violation of Subsection 412.7;
 - (2) Failing to keep swimming pool, spa pool or sauna, or pool deck free of sediment, floating debris, visible dirt and algae in violation of Subsection 504.6;
 - (3) Violations of recent editions of the District of Columbia's Construction Codes Supplements, as specified in Subsection 102.1(l) and Chapter 6;
 - (4) A drowning hazard;
 - (5) Broken glass, sharp edged or broken tile, metal, or other abrasion hazards in the water or deck area;
 - (6) Operating an aquatic facility with a fire;

- (7) Operating an aquatic facility with a flood;
- (8) Operating an aquatic facility with an interruption of municipal water service;
- (9) Operating an aquatic facility with a sewage backup;
- (10) Operating an aquatic facility with an onset of a confirmed waterborne illness;
- (11) An unapproved modification to a swimming pool, spa pool, or sauna determined by the Department to be unsanitary or dangerous to the public health, safety, or welfare;
- (12) Operating an aquatic facility with unprotected, overhead electrical wires within twenty (20) feet horizontally of the water of a swimming pool, spa pool, or sauna;
- (13) Operating an aquatic facility without a ground-fault circuit interrupter (GFCI) within twenty (20) feet of the inside wall of the aquatic facility designed to shut off electric power to protect people against electric shock from an electrical system or outlet; or
- (14) Operating an aquatic facility with a recirculation system or automatic disinfectant chemical feeding equipment is missing, malfunctioning, or not functioning.

715.3 When any of the conditions listed in Subsections 715.1 or 715.2 of these regulations exist, the Department shall attach a sign that states:

AQUATIC FACILITY CLOSED. This facility is closed until further notice by the Department of Health for imminent health hazard(s) in violation of Section 715 of the District's Aquatic Facilities Regulations (Swimming Pools, Spa Pools, and Saunas in Subtitle C, Title 25 of the District of Columbia Municipal Regulations).

716 IMMEDIATE HEALTH HAZARD — RESUMPTION OF FACILITY OPERATIONS*

716.1 If the facility is closed as specified in Section 715, the licensee shall obtain approval from the Department as specified in Section 811 before resuming operations.

717 CRITICAL VIOLATIONS — TIME FRAME FOR CORRECTION

717.1 A licensee shall, at the time of inspection, correct a critical violation of these regulations immediately, except as specified in Subsection 717.2.

717.2 The Department may consider the nature of the potential hazard involved and the complexity of the corrective action needed and agree to specify a longer timeframe, not to exceed five (5) calendar days after the inspection, for the licensee to correct a critical violation of this Regulation.

717.3 Failure to correct violations in accordance with this section may subject a licensee to summary suspension of license pursuant to Section 807, revocation or suspension of a license pursuant to Section 812, and the issuance of Notice of Infractions pursuant to Section 1000, and civil penalties pursuant to Section 1001.

718 CRITICAL VIOLATIONS – VERIFICATION AND DOCUMENTATION OF CORRECTION

718.1 After observing at the time of inspection a correction of a critical violation, the Department shall enter the violation and information about the corrective action on its inspection report.

718.2 After receiving notification that the licensee has corrected a critical violation, the Department shall verify correction of the violation, document the information on an inspection report, and enter the report in its records.

719 NONCRITICAL VIOLATIONS – TIME FRAME FOR CORRECTION

719.1 The licensee shall correct noncritical violations by a date and time agreed to or specified by the Department but no later than fourteen (14) calendar days after the inspection, except as specified in Subsection 719.2.

719.2 The Department may approve a compliance schedule that extends beyond the time limits specified in Subsection 719.1 if the licensee submits a written schedule of compliance and no health hazard exists or will result from allowing an extended schedule for compliance.

719.3 Failure to correct violations in accordance with this section may result in the revocation or suspension of a license pursuant to Section 812, and the issuance of Notice of Infractions pursuant to Section 1000, and civil penalties pursuant to Section 1001.

720 REQUEST FOR REINSPECTION

720.1 If a license is summarily suspended pursuant to Section 807 or suspended or revoked pursuant to Section 812 because of violations of this Regulation, the licensee shall submit to the Department a written request for reinspection.

- 720.2 Upon receipt of a request for reinspection, the Department shall perform the reinspection of the public swimming or spa facility within three (3) business days of receipt of the request.
- 720.3 A swimming pool, spa pool, or sauna facility shall not resume operations, use of equipment, chemicals or supplies, or remove from public view any Department posted closures, warnings, inspection reports, or orders until the Department has reinspected the swimming pool, spa pool, or sauna facility and certified that it is in compliance with these Regulations, as specified in Sections 716.1, 720.1, 720.2, 804, and 805.

CHAPTER 8 ADMINISTRATIVE ENFORCEMENT ACTIONS AND ORDERS

800 ADMINISTRATIVE ENFORCEMENT ACTION – REMEDIES

- 800.1 The Department may use one or more of the remedies listed in this chapter simultaneously to address a violation of this Regulation.

801 ADMINISTRATIVE ENFORCEMENT ACTION – CONDEMNATION ORDER, JUSTIFYING CONDITIONS AND REMOVAL OF EQUIPMENT, CHEMICALS, OR OTHER OPERATIONAL SUPPLIES

- 801.1 A duly authorized agent of the Department may condemn and cause to be removed any equipment, chemicals, or other operational supplies found in a swimming pool, spa pool, or sauna facility the use of which does not comply with these regulations.

802 ADMINISTRATIVE ENFORCEMENT ACTION – CONDEMNATION ORDER, CONTENTS

- 802.1 The condemnation order shall:
- (a) State that the equipment, chemicals, or other operational supplies subject to the order may not be used, sold, moved from the swimming pool, spa pool, or sauna facility or destroyed without a written release of the order from the Department;
 - (b) State the specific reasons for placing the equipment, or other operational supplies under the condemnation order with reference to the applicable provisions of these regulations and the hazard or adverse effect created by the observed condition;
 - (c) Completely identify the equipment, chemicals, or other operational supplies subject to the condemnation order by the common name, the manufacturer's information, description of the item, the quantity, the Department's tag or identifying information, and location;

- (d) State that the Department of Health may order the destruction, replacement or removal of the equipment, chemicals, or other operational supplies; and
- (e) That the licensee may request an informal conference in accordance with Subsection 803.2. A request for an informal conference does not stay the Department's imposition of the condemnation order.

803 ADMINISTRATIVE ENFORCEMENT ACTION — CONDEMNATION ORDER, OFFICIAL TAGGING OR MARKING OF EQUIPMENT, CHEMICALS, OR OTHER OPERATIONAL SUPPLIES

- 803.1 The Department of Health shall place a tag, label, or other appropriate marking to indicate the condemnation of equipment, chemicals, or other operational supplies that do not meet the requirements of this Regulation.
- 803.2 The tag or other method used to identify the equipment, chemicals, or other operational supplies that are the subject of a condemnation order shall include a summary of the provisions specified in Section 802 and shall be signed and dated by the Department.

804 ADMINISTRATIVE ENFORCEMENT ACTION — CONDEMNATION ORDER, EQUIPMENT, CHEMICALS, OR OTHER OPERATIONAL SUPPLIES MAY NOT BE USED OR MOVED

- 804.1 Equipment, chemicals, or other operational supplies that are subject to a condemnation order may not be used, sold, moved, or otherwise destroyed by any person, except as specified in Subsection 804.2.
- 804.2 The Department may allow the licensee to store the equipment, chemicals, or other operational supplies in an area of the swimming pool, spa pool, or sauna that does not restrict the facility's operations.

805 ADMINISTRATIVE ENFORCEMENT ACTION — CONDEMNATION ORDER, REMOVING THE OFFICIAL TAG OR MARKING

- 805.1 No person shall remove Department posted tags, labels, or other appropriate markings except under the direction of the Department as specified in Subsection 805.2.
- 805.2 The Department of Health shall issue a notice of release from a condemnation order and shall remove condemnation tags, labels, or other appropriate markings from equipment, chemicals, or other operational supplies if:
- (a) The condemnation order is vacated; or

- (b) The licensee notifies the Department that the equipment, chemicals, or other operational supplies have been modified to meet NSF/ANSI or ASME/ANSI standards and the requirements of this Regulation, and the Department has conducted a re-inspection.

806 ADMINISTRATIVE ENFORCEMENT ACTION — CONDEMNATION ORDER, WARNING OR INFORMAL CONFERENCE NOT REQUIRED

806.1 The Department may issue a condemnation order to a licensee without prior warning, or informal conference on the condemnation order.

806.2 A condemnation order shall be reviewed by a Department program manager or supervisor prior to it being issued to an operator. A request by email, certified mail, or fax may be submitted by the licensee requesting an informal conference with the Department within fifteen (15) business days of receiving the condemnation order.

807 ADMINISTRATIVE ENFORCEMENT ACTION — SUMMARY SUSPENSION OF LICENSE, CONDITIONS WARRANTING ACTION

807.1 The Department may summarily suspend a license to operate a swimming pool, spa pool, or sauna facility, when the Department is denied access to a facility in violation of Section 710, or when the Department determines through an inspection, examination of records, or other means as specified in the Regulations that an imminent health hazard exists.

808 ADMINISTRATIVE ENFORCEMENT ACTION — CONTENTS OF SUMMARY SUSPENSION NOTICE

808.1 A summary suspension notice shall state:

- (a) That the license of a swimming pool, spa pool, or sauna facility is immediately suspended and that all operations shall immediately cease;
- (b) The reasons for summary suspension with reference to the provisions of this Regulation that are in violation;
- (c) The name and address of the Department's representative to whom a written request for reinspection may be made and who may certify that reasons for the suspension are eliminated; and
- (d) State that the licensee may request an informal conference in accordance with Subsection 809.2. A request for an informal conference does not stay the Department's imposition of the condemnation order;

809 ADMINISTRATIVE ENFORCEMENT ACTION — SUMMARY SUSPENSION, WARNING OR INFORMAL CONFERENCE NOT REQUIRED

809.1 The Department may summarily suspend a license as specified in Section 807 by providing written notice as specified in Section 808 of the summary suspension to the licensee, without prior warning or informal conference.

809.2 A Notice of Summary Suspension shall be reviewed by a Department program manager or supervisor prior to being issued to a licensee. A request by email, certified mail, or fax may be submitted by a licensee requesting an informal conference with the Department.

810 ADMINISTRATIVE ENFORCEMENT ACTION — SUMMARY SUSPENSION, TIME FRAME FOR REINSPECTION

810.1 After receiving a request by email, certified mail, or fax from the licensee stating that the conditions cited in the summary suspension order no longer exist, the Department shall conduct a reinspection of the aquatic facility for which the license was summarily suspended within three (3) business days of receiving the licensee's request.

811 ADMINISTRATIVE ENFORCEMENT ACTION — SUMMARY SUSPENSION, TERM OF SUSPENSION, REINSTATEMENT

811.1 A summary suspension shall remain in effect until the conditions cited in the notice of suspension no longer exist and the Department has confirmed, through reinspection or other appropriate means that the conditions cited in the notice of suspension have been corrected, as specified in Section 716 and 720.

812 ADMINISTRATIVE ENFORCEMENT ACTION — REVOCATION OR SUSPENSION OF LICENSE, OR DENIAL OF APPLICATION OR RENEWAL OF LICENSE

812.1 Failure to comply with any of the provisions of these regulations shall be grounds for the revocation or suspension of any license issued to an aquatic facility pursuant to the Department of Health Functions Clarification Act of 2001, effective October 3, 2001, as amended (D.C. Law 14-28; D.C. Official Code § 7-731(b) (2012 Repl.)). The Department may revoke a license of a swimming pool, spa pool, or sauna where there is a record of subsequent violations and a history of summary suspensions within a three (3) year period.

812.2 Before a license is revoked, or suspended, a licensee shall be given an opportunity to answer and to be heard on the violations before the Office of Administrative Hearings in accordance with the Office of Administrative Hearings Rules of Practice and Procedure in Section 2808, Title 1 DCMR, as amended.

- 812.3 Before the Department denies an application for license, or denies the renewal of a license as specified in Section 703, an applicant or licensee shall be given an opportunity to answer and to be heard on the violations before the Office of Administrative Hearings in accordance with the Office of Administrative Hearings Rules of Practice and Procedure in Section 2808, Title 1 DCMR, as amended.

CHAPTER 9 SERVICE OF PROCESS

900 SERVICE OF PROCESS – NOTICE, PROPER METHODS

- 900.1 A notice issued in accordance with these regulations shall be deemed properly served if it is served by one (1) of the following methods:
- (a) A Department representative, a law enforcement officer, or a person authorized to serve a civil process, personally services the notice to the licensee, or the person operating a swimming pool, spa pool, or sauna without a license;
 - (b) The Department sends the notice to the last known address of the licensee or person operating a swimming pool, spa pool, or sauna without a license, in accordance with Section 205 of the Department of Consumer and Regulatory Affairs Civil Infractions Act of 1985, effective October 5, 1985 (D.C. Law 6-42; D.C. Official Code § 2-1802.05 (2012 Repl.)), or by other public means so that a written acknowledgment of receipt may be acquired; or
 - (c) In accordance with the Office of Administrative Hearings Rules of Practice and Procedure in Section 2811, Title 1 DCMR, as amended.

901 SERVICE OF PROCESS – DEPARTMENT ISSUED NOTICES OF SUMMARY SUSPENSION, NOTICES OF INFRACTION, AND OTHER DIRECTIVES

- 901.1 Notices of Summary Suspension, Notices of Infraction, and other directives issued by the Department shall be:
- (a) Served as specified in Subsection 900.1; or
 - (b) Posted by the Department at a public entrance to the swimming pool, spa pool, or sauna.

902 SERVICE OF PROCESS – NOTICE, EFFECTIVENESS

902.1 Service is effective at the time of the notice's receipt as specified in Subsection 901.1(a), or if service is made as specified in Subsection 901.1(b) at the time of the notice is posted.

903 SERVICE OF PROCESS – PROOF OF PROPER SERVICE

903.1 Proof of proper service may be made by certificate of service signed by the person making service or by admission of a return receipt, certificate of mailing, or a written acknowledgment signed by the licensee or person operating a swimming pool, spa pool, or sauna without a license or an authorized agent.

CHAPTER 10 ADMINISTRATIVE AND CIVIL PENALTIES, AND JUDICIAL REVIEW

1000 NOTICE OF INFRACTIONS

1000.1 The Department may impose civil infraction fines penalties for violations of any provision of these regulations pursuant to the Department of Consumer & Regulatory Affairs Civil Infractions Act of 1985, (Civil Infraction Act), effective October 5, 1985 (D.C. Law 6-42; D.C. Official Code §§ 2-1801 *et seq.* (2012 Repl.)).

1000.2 A licensee who receives a Notice of Infraction as specified in Subsection 900.1(c), may pay the assessed fine or appear before the Office of Administrative Hearings as directed on the reverse side of the Notice of Infraction in accordance with the “Office of Administrative Hearings Rules of Practice and Procedure” in Section 2808, Title 1 DCMR, as amended.

1001 CIVIL FINES AND PENALTIES

1001.1 Civil fines, penalties, or related costs may be imposed against any aquatic facility owner, or licensee for violation of any provision of this Regulation.

1002 JUDICIAL REVIEW – APPEALS

1002.1 Any person aggrieved by a final order or decision of the Department may seek judicial review in accordance with the Department of Health Functions Clarification Act of 2001, effective October 3, 2001, as amended (D.C. Law 14-28; D.C. Official Code § 7-731(b) (2012 Repl.)).

1003 [RESERVED – FEE AND SERVICE SCHEDULE]

CHAPTER 99 DEFINITIONS

9900 GENERAL PROVISION AND DEFINITIONS

9900.1 The terms and phrases used in this title shall have the meanings set forth in this chapter, unless the text or context of the particular chapter, section, subsection, or paragraph provides otherwise.

9900.2 DEFINITIONS

Abrasion hazard – a sharp or rough surface that would scrape the skin by chance during normal use.

Accessible – easy exposed for inspection and the replacement of materials and/or parts with the use of tools.

Agitated water – an aquatic venue with mechanical means (aquatic features) to discharge, spray, or move the water's surface above and/or below the static water line of the aquatic venue. Where there is no static water line, movement shall be considered above the deck plane.

Algae – a marine plant classified along with Fungi and Bacteria in the group *Thallophyta*; thrives in sunny places on land or water utilizing photosynthesis for energy production; and can be destroyed easily with chlorine sanitizers.

Alteration – any change in equipment or materials used in the construction of a public swimming pool, spa pool, or sauna that does not conform to DCRA or DOH-approved plans, specifications, and change orders. Or, any act which changes or alters the original characteristics of the pool that requires a Building Permit issued by DCRA or DOH-approval, including but not limited to: pool or deck resurfacing, painting, equipment changes, structural additions or deletions, including but not limited to changes in the recirculation systems, decking, treatment systems, disinfection system, or pool shape modifications.

ASME/ANSI – a safety standard accredited by the American National Standards Institute and published by the American Society of Mechanical Engineers.

Aquatic feature – an individual component within an aquatic facility, such as slides, structures designed to be climbed or walked across, and structures that create falling or shooting water.

Aquatic facility – an artificially constructed structure or modified natural structure where the general public is exposed to water intended for recreational or therapeutic purpose. Such structures do not necessarily contain standing water, so water exposure may occur via contact, ingestion, or aerosolization. Examples include swimming pools, wave pools, lazy rivers, surf pools, spas (including spa pools and hot tubs),

therapy pools, waterslide landing pools, spray pads, and other interactive water venues.

Barrier – a fence, safety cover, wall, building wall or a combination thereof, which completely surrounds or covers the swimming pool or spa and obstructs access to the swimming pool, or spa pool, including a natural or constructed topographical feature that prevents unpermitted access by bathers to a swimming pool, and with respect to a hot tub, a lockable cover. All access through the barrier shall have (1) one or more of the following safety features: alarm, key lock or self-locking or self-latching doors and gates.

Bather – any person using a swimming pool, spa pool, or sauna and adjoining deck area for the purpose of water sports, recreation therapy or related activities.

Bather load – the maximum number of persons allowed in the pool / spa area at one time.

Beginners' areas – water depths of three feet (3 ft.) or zero point nine one four four meter (0.9144 m) or less.

Breakpoint Chlorination – elimination of inorganic chloramines by adding enough Free Chlorine to destroy the inorganic chloramines that contribute to combined chlorine. Ten times the Combined Chlorine minus the existing Free Chlorine is used.

Bromine – a chemical sanitizing agent that is not as effective as chlorine in normal conditions and is not affected by heat, and continues disinfecting after combining making it great for spas.

Chemical feeder – a mechanical device used for applying chemicals to the water in swimming pools, spa pools, and saunas.

Chloramine – a compound formed when chlorine combines with nitrogen or ammonia causing eye and skin irritations and has a strong, objectionable odor.

Chlorination – the process of introducing chlorine to water to remove undesired contaminants and acts as a sanitizer, algaecide and strong oxidizer.

Circulation equipment – the mechanical components that are part of a circulation system in a swimming pool, spa pool, or sauna. Circulation equipment includes but is not limited to categories of pumps, hair and lint strainers, filters, valves, gauges, meters, heaters, surface skimmers, inlet/outlet fittings, and chemical feeding devices. The components have

separate functions, but when connected to each other by piping, perform as a coordinated system for purposes of maintaining swimming pool, spa pool, or sauna in a clear, sanitary and desirable condition.

Circulation system – an arrangement of mechanical equipment or components, connected by piping to a swimming pool, spa pool, or sauna in a closed system. The function of a circulation system is to direct water from the pool or spa, causing it to flow through the various system components for purposes of clarifying, heating, purifying, and returning the water back to the original body of water.

Clarifier – a chemical that coagulates and neutralizes suspended particles in water. There are two (2) types: inorganic salts of aluminum or iron and water-soluble organic polyelectrolyte polymers, also called coagulant or flocculent.

Coliform – a group of naturally-occurring bacteria that are present in all surface water and are in the intestinal tract of human and other warm-blooded animals. The presence of coliforms in a swimming pool, spa pool, or sauna indicates possible deficiencies in chlorine residuals, water clarity, filter backwashing or cleaning, pool cleanliness, swimmer adherence to showering rules and/or proper sample collection technique.

Colorimetric – one of four (4) test methods used to determine the concentration of a chemical element or chemical compound in a solution with the aid of a color reagent.

Competition pool – a swimming pool designed to be routinely used to host organized swim competitions such as those sponsored by colleges, universities, swim leagues, and swim clubs.

Coping – edge between deck of pool and water.

Critical item – a provision of these regulations that, if in noncompliance, is more likely than other violations to serve as a vector for a waterborne illness, or an environmental health hazard. A critical item is denoted with an asterisk (*).

Critical limit – the maximum or minimum value to which a physical, biological, or chemical parameter must be controlled at a critical control point to prevent, eliminate or reduce to an acceptable level the occurrence of a waterborne illness, or an environmental health hazard.

Critical violation – a condition or practice that violates these regulations and results in a waterborne illness, or endangers the public health, safety, or welfare.

Cyanuric – a chemical that helps reduce the excess loss of chlorine in water due to the ultraviolet rays of the sun. It is also called stabilizer, isocyanuric acid conditioner or triazinetrione.

Dark – a Munsell Color Value from zero (0) to four (4).

DCRA – Department of Consumer and Regulatory Affairs

Decks – those areas immediately adjacent to or attached to a swimming pool, spa pool, or sauna that are specifically constructed or installed for use by users sitting, standing or walking.

Deep areas – water depths in excess of five feet (5 ft.) or one point five two four meters (1.524 m).

Department or DOH – Department of Health.

D.E. – the Diatomaceous Earth that is used as a filter aid in DE type filters, including alternative filter aids that have been approved under NSF / ANSI Standard 50-2007, and accepted by the filter manufacturer.

Disinfectant – energy or chemicals used to kill undesirable or pathogenic (disease-causing) organisms that have a measurable residual at a level adequate to make the desired kill.

Diving board – a recreational mechanism for entering a swimming pool, consisting of a semi-rigid board that derives its elasticity through the use of a fulcrum mounted below the board.

Duckboard – a boardwalk laid across a muddy ground or flooring; made of non-porous easily cleanable material when used in pool deck area.

Electronic – one of four (4) test methods used to determine the concentration of a chemical using a portable/hand held test meter for pool-side use.

Ground-fault circuit interrupter (GFCI) – a fast-acting circuit breaker designed to shut off electric power in the event of a ground-fault (a break in the low-resistance grounding path from a tool or electrical system) within as little as 1/40 of a second, as defined by the U.S. Department of Labor Occupational Safety & Health Administration (OSHA) in publication OSHA 3007 1998 (Revised), an informational booklet.

Hose bibb – any connection to a potable water supply.

Imminent health hazard – a significant threat or danger to health that is considered to exist when there is evidence sufficient to show that a product, practice, circumstance, or event creates a situation that requires immediate correction or cessation of operations to prevent injury based on the number of potential injuries, and the nature, severity and duration of the anticipated injury.

Inaccessible – enclosed by an effective barrier.

Jump board – a recreational mechanism that has a coil spring, leaf spring or comparable device located beneath the board which is activated by the force exerted in jumping on the board.

Licensee – the owner of an aquatic facility.

Lifeguard – a person having the qualifications of and possessing a current American Red Cross, YMCA, or other Lifeguard Certifications, current First Aid Certificates, current CPR (which includes adult, child, and infant), Certificates issued by nationally recognized aquatic training organizations, such as the International Lifeguard Training Program™ (ILTP™), that are adopted and recognized by the D.C. Department of Health; and is responsible for the safety of the users of a public swimming pool, spa pool, and sauna.

Main drain – a submerged suction outlet typically located at the bottom of a swimming pool, spa pool, and sauna to conduct water to a re-circulating pump.

Marking or Markings – the placement and installation of visual marking cues to help patrons identify step, bench and swim out outlines, slope break location, depth designations, and NO ENTRY and NO DIVING warnings. When markings are specified to be dark the term “dark” shall have the meaning defined in this Regulation.

Membrane filter test – a swab sample taken from any hard surface.

N,N-Diethyl-p-Phenylenediamine (DPD) – pH indicator in liquid or tablet form is the most common chlorine/bromine testing reagent; the indicator turns pink in the presence of disinfectant residual and the pinker the sample, the higher the chlorine/bromine reading.

NTU (Nephelometric Turbidity Unit) – a means of measuring water clarity.

Oxidation reduction potential (ORP) controller – device used to measure sanitizer effectiveness and to control ozone generators, chlorine

generators, and ionizers (in combination with chlorine). ORP is the only practical method to electronically monitor sanitizer effectiveness.

Oxidation reduction potential (ORP) – a measure of the tendency for a solution to either gain or lose electrons; higher (*more positive*) oxidation reduction potential indicates a more oxidative solution.

Pool safety cover – a manually or power-operated safety pool cover that conforms to the entrapment protection standards of the ASME/ANSI A112.19.8 performance standard, or any successor standard regulating swimming pools or drain covers.

Pool and Spa Operator – an individual directly responsible for the operation of a swimming pool, spa pool, and sauna facility with certifications that are registered by the National Swimming Pool Foundation, and who are in possession of a current District of Columbia Pool and Spa Operator's Registration Card.

Precoat – the layer of diatomaceous earth deposited on the filter septa at the start of a filter run with D.E. filters.

Precoat feeder – a chemical feeder designed to inject diatomaceous earth into a filter in sufficient quantity to coat the filter septa at the start of a filter run.

Private residential swimming pools, spa pools, and saunas – residential swimming pool, spa pool, or sauna built in conjunction with a single family residence used or intended to be used solely by the owner or lessee, and the owner or lessee's immediate family and guests invited to use it without payment of a fee.

Public pool – any public pool or pools serving multi-family units, as classified and defined within this definition that are used for swimming or bathing and are operated by an owner, lessee, operator, licensee, or concessionaire, regardless of whether a fee is charged for use. Public pools shall be further classified and defined as follows:

- (a) Class A, Competition Pool – any pool intended for use for accredited competitive aquatic events such as Federation Internationale De Natation (FINA), USA Swimming, USA Diving, USA Synchronized Swimming, USA Water Polo, National Collegiate Athletic Association (NCAA), or National Federation of State High School Associations (NFHS). The use of the pool is not limited to competitive events.
- (b) Class B, Municipal Pool – any pool intended for public recreational use.

- (c) Class C, Semi-Public Pool – any pool operated solely for and in conjunction with lodgings such as hotels, motels, apartments, condominiums.
- (d) Class D-1, Wave Action Pool – a pool designed to simulate breaking or cyclic waves for purposes of general play or surfing.
- (e) Class D-2, Activity Pool – a pool designed for casual water play ranging from simple splashing activity to the use of attractions placed in the pool for recreation.
- (f) Class D-3, Catch Pool – a body of water located at the termination of a manufactured waterslide attraction. The body of water is provided for the purpose of terminating the slide action and providing a means for exit to a deck or walkway area.
- (g) Class D-4, Leisure River – a manufactured stream of water of near-constant depth in which the water is moved by pumps or other means of propulsion to provide a river-like flow that transports bathers over a defined path that may include water features and play devices.
- (h) Class D-5, Vortex Pool – a circular pool equipped with a method of transporting water in the pool for the purpose of propelling riders at speeds dictated by the velocity of the moving stream of water.
- (i) Class D-6, Interactive Play Attraction – a manufactured water play device or a combination of water-based play devices in which water flow volumes, pressures, or patterns can be varied by the bather without negatively influencing the hydraulic conditions for other connected devices. These attractions incorporate devices or activities such as slides, climbing and crawling structures, visual effects, user-actuated mechanical devices and other elements of bather-driven and bather-controlled play.
- (j) Class D-7, Amusement Park Attraction – an attraction or ride traditionally found in amusement parks that are designed to permit bather contact with water.
- (k) Class D-8, Natural Body of Water – a natural or man-made aquatic play area normally regarded as oceans, lakes, ponds, streams, quarries, or bodies of water that the local jurisdiction has designated as natural bodies of water.

- (l) Class E – pools used for instruction, play or therapy and with temperatures above eighty-six degrees Fahrenheit (86° F) or (thirty degrees Celsius (30.0 ° C). Public pools are either a diving or non-diving type. Diving types of public pools are classified into types as an indication of the suitability of a pool for use with diving equipment.
- (m) Type VI-IX – public pools suitable for the installation of diving equipment by type.
- (n) Type O – a non-diving public pool.

Qualified lifeguards – individuals who have successfully completed nationally recognized aquatic training organizations adopted and recognized by the D.C. Department of Health, hold current certificates for such training, have met the pre-service requirements, and are participating in continuing in-service training requirements of the aquatic facility.

Quaternary ammonium (quats) – a compound derived from ammonium with hydrogen atoms replaced by organic groups; used as surface-active agent and disinfectant.

Recirculation system – a system consisting of pumps, motors, piping, filters, inlets, outlets, disinfecting and other water conditioning equipment and necessary accessories.

Return – pool water that is going back into the filtration system and chemical feeding cycle, usually from the gutters, skimmer or return lines.

Safety vacuum release system – a vacuum release system capable of providing vacuum release at a suction outlet caused by a high vacuum occurrence due to a suction outlet flow blockage.

Sauna – aquatic feature including but not limited to the application of water vapor from hot water facilities such as Jacuzzis, hot tubs and steam baths.

Scum gutter - overflow line along the sides of the swimming pool, spa pool, and sauna that takes water to the return lines in the filtration system.

Shallow end of pool – the portion of a pool where the water's depth is four feet (4 ft.) or less.

Shepherd's hook – a pole twelve (12) to sixteen (16) feet in length with a loop on the end to grasp a person in the water who is in distress without entering the water.

Ship's ladder – the entry and exit ladders found on the pool sides and ends.

Showers – baths where the bather's body is sprayed with a fine stream of water from small jets.

Skimmer or surface skimmer – overflow water line that traps debris in the weir basket and returns the water to the filtration system for treatment.

Slip resistant – having a textured surface which is not conducive to slipping under contact of bare feet unlike glazed tile or masonry terrazzo and non-textured plastic materials. Manufactured surface products shall be designed by the manufacturer as suitable for walking surfaces in wet areas. Minimum acceptable static coefficient of friction to determine slip resistance is 0.7 on horizontal wet walking surfaces in the pool and for the wet deck area.

Spa pool – a structure intended for either warm or cold water where prolonged exposure is not intended. Spa structures are intended to be used for bathing or other recreational uses and are not usually drained and refilled after each use. It may include, but is not limited to, hydrotherapy, air induction bubbles, and recirculation.

Stationary diving platform – used for diving and are constructed or located on site, and may be natural or artificial rocks, pedestals or other items.

Super-chlorination – the addition of large quantities of chlorine-based chemicals that kills algae, destroys odor, or improves the ability to maintain a disinfectant residual.

Titrimetric – one of four (4) test methods used to determine the unknown concentration of a chemical by using a standard concentration of a known reagent.

Turbidimetric – one of four (4) test methods used to measure the amount of solid particles that are suspended in water and that cause light rays shining through the water to scatter and appear cloudy.

Turnover time – the period of time (usually hours) required to circulate the complete volume of water in a pool through the recirculation system.

Unblockable drain – a drain of any size and shape that a human body cannot sufficiently block to create a suction entrapment hazard.

UL Standard – a document published by UL, a global independent safety science company, detailing construction, performance, environmental, sustainability or other requirements utilized for certification.

Vacuum breakers – a plumbing device that prevents the pool’s recirculation pumps from being damaged by shutting the system down when there is a drop in air pressure.

Water Ionizer – an appliance that filters and converts water into ions; separates *water* into an alkaline fraction and an acid fraction by exploiting the *electric charge* of the *calcium* and *magnesium ions* present in nearly all sources of *drinking water*. In the case of water chemistry sodium hypochlorite (liquid bleach) is converted into hypochlorous acid (HClO), the active sanitizing agent in pool water.

Water recreation attraction – a facility with design and operational features that provide patron recreational activity and purposefully involves immersion of the body partially or totally in the water. Water recreation attractions include water slides, water activity pools, interactive water features, wave pools and any additional pool within the boundaries of the attraction.

Water-safe – a bather who is able to swim and capable of exercising proper judgment in taking action for self-preservation under emergency conditions.

Water therapy facilities – swimming pools, spa pools, or saunas used exclusively for water therapy to treat a diagnosed injury, illness, or medical condition, wherein the medical treatment or physical therapy is provided under the direct supervision of medical personnel licensed pursuant to the Health Occupations Revision Act of 1985 Amendment Act of 1994, effective March 23, 1995 (D.C. Law 10-247; D.C. Official Regulation § 3-1205.01 (2016 Repl.)); and the prescribing physician authorizes a plan of treatment justifying use of a pool for health care purposes.

Weir – baskets found at the skimmer line that trap and prevent debris from entering the filtration system in the return lines which could damage the pumps or obstruct the filters.

Wet deck area – the four foot wide unobstructed pool deck area around the outside of the pool water perimeter, curb, ladders, handrails, diving boards, diving towers, pool slides, waterfalls, water features, starting blocks, planters, or lifeguard chairs.

Zones of patron surveillance – when qualified lifeguards are used, the staffing plan shall include diagrammed “zones of patron surveillance” for each aquatic facility where:

- (a) A qualified lifeguard is capable of viewing the entire area of the assigned “zones of patron surveillance”;
- (b) A qualified lifeguard is able to reach the furthest extent of the assigned “zones of patron surveillance” within 20 seconds;
- (c) Identify whether a qualified lifeguard is in an elevated stand, walking, in-water and/or other approved position;
- (d) Identifying any additional responsibilities for each zone; and
- (e) All areas of each aquatic venue are assigned a “zones of patron surveillance”.